

PORTABLE FIRE PUMP
PFP-11hpHND-M
GX340 HONDA WITH HIGH-VOLUME PUMP

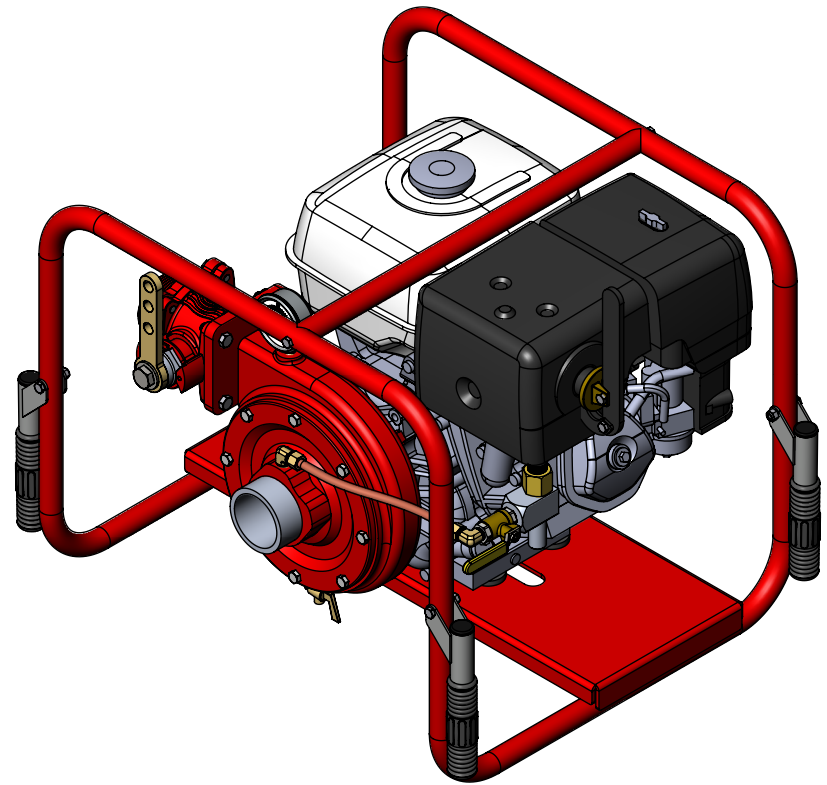

WE CAN CUSTOMIZE AS YOU WANT

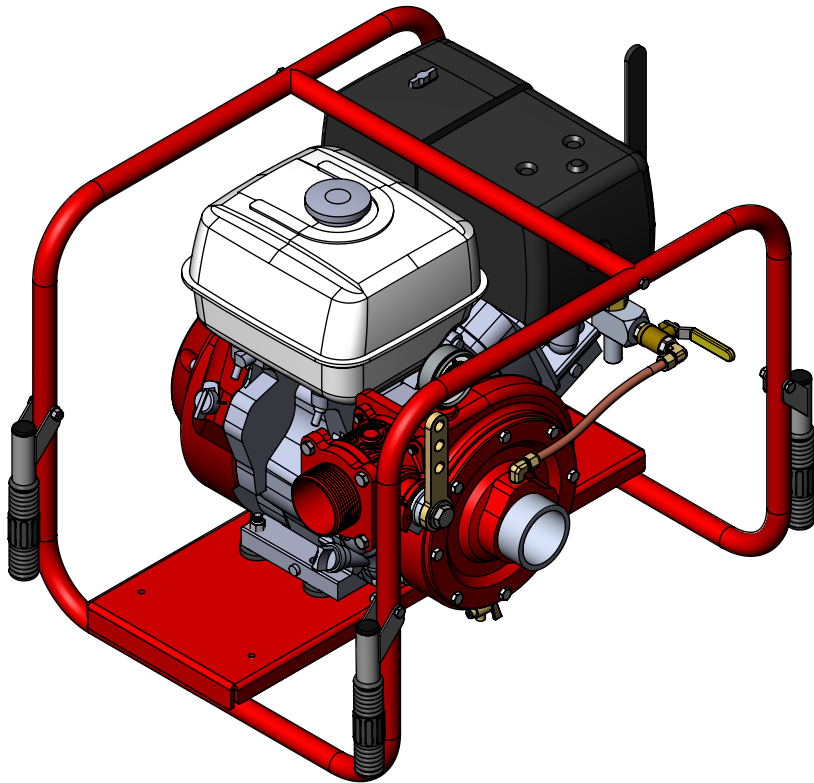
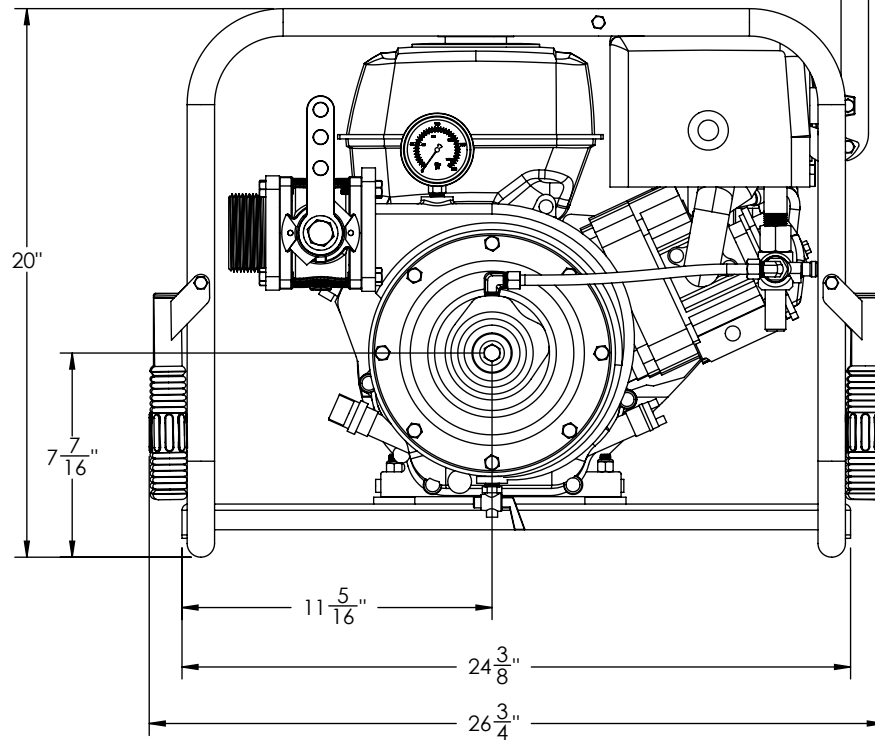
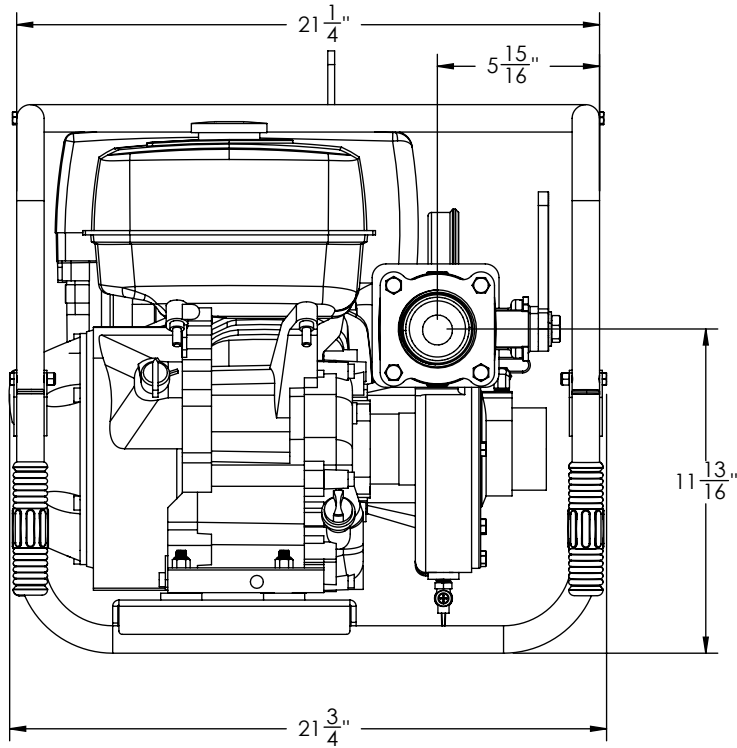

WET WEIGHT: 115 lbs



nqa.
 ISO 9001
 Registered
 Quality
 Management

CREATED
 BY: M.P.
 DATE: 01-09-16
VERIFIED
 BY: M.P.
 DATE: 01-09-16

TITLE : PFP-11hpHND-M
 FULL FRAME
No: PO-2511-0701-A

WARNING

THIS DOCUMENT REMAINS THE PROPERTY OF C.E.T. FIRE PUMPS MFG.
 ALL REPRODUCTION WITHOUT WRITTEN AGREEMENT FROM C.E.T. FIRE PUMPS MFG IS TOTALLY PROHIBITED.

REV.	DESCRIPTION	DATE	BY
A	Version A	01-01-16	M.P.

NO	PART NUMBER	DESCRIPTION	QTY
1	001-PP1-003	HONDA ENGINE (GX340) ELECTRIC/MANUAL	1
2	003-PP1-054	AIR FILTER	1
3	005-PP1-205	BALL VALVE 1/4" NPT-F	1
4	010-PP1-999	COPPER TUBE 3/8" x 9-1/4"	1
5	022-PP1-009	HEX. BOLT 3/8"-16 x 2" (Gr.5 ZINC)	4
6	023-PP1-001	HEX. NYLON LOCKNUT 3/8"-16	4
7	024-PP1-009	FLAT WASHER 3/8" int. x 7/8" ext.	4
8	025-PP1-015	RUBBER WASHER 0.312" INT x 1.5" EXT. x 1/4" TK	4
9	045-PP1-048	CLOSE NIPPLE 1/4 NPT-M	1
10	045-PP1-132	COMP. 90deg. ELBOW 3/8" TUBE x 1/4" NPT-M	2
11	PO-0000-1712	FULL FRAME	1
12	PO-0000-4102	VENTURY	1
13	PO-0000-5722	MUFFLER	1
14	PO-2511-0801	PUMP END ACCESSORIES ASSEMBLY	1

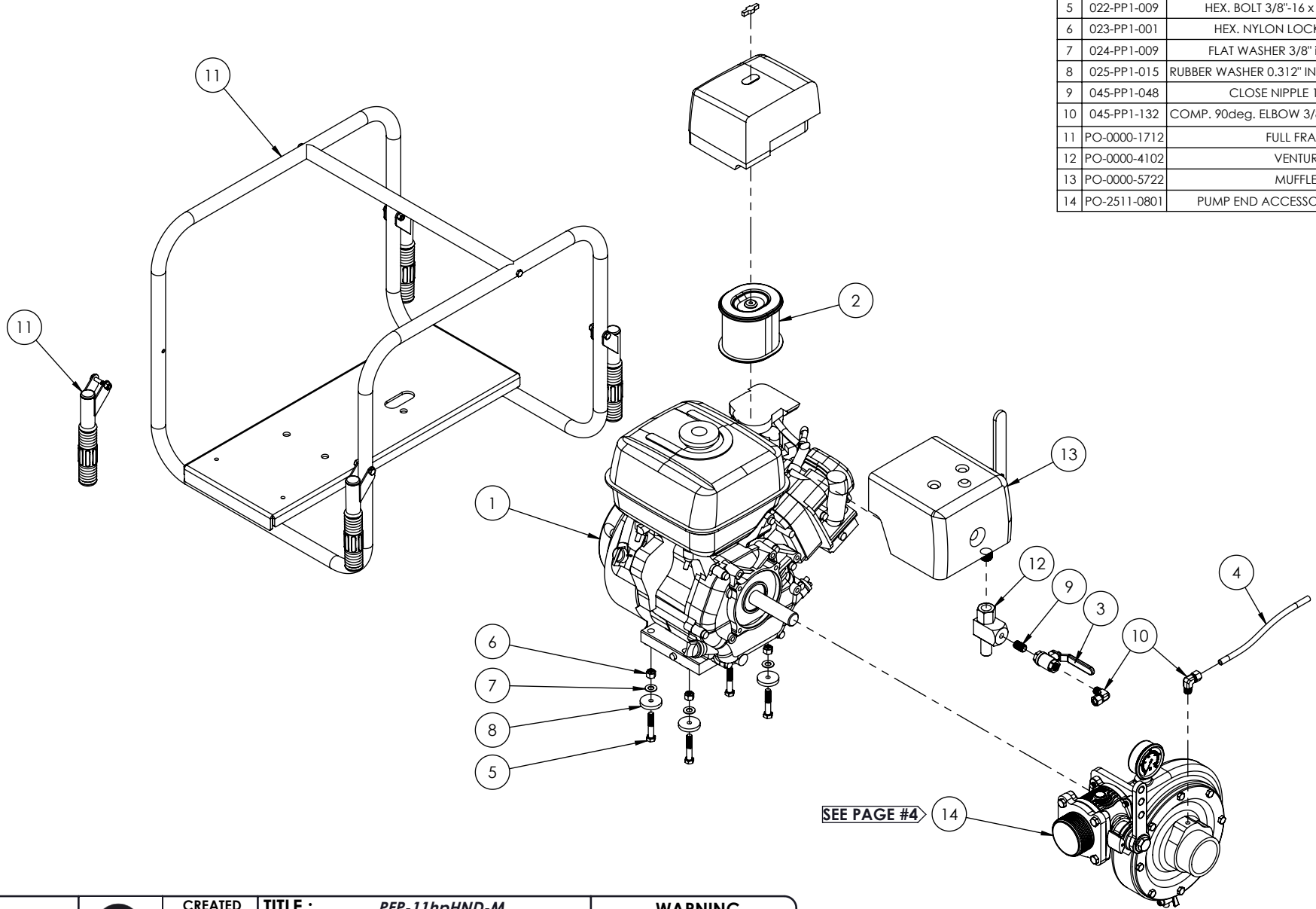

nqa.
ISO 9001
Registered
Quality
Management

CREATED
BY: M.P.
DATE: 01-09-16
VERIFIED
BY: M.P.
DATE: 01-09-16

TITLE : PFP-11hpHND-M
FULL FRAME
No: PO-2511-0701-A

WARNING
THIS DOCUMENT REMAINS THE PROPERTY
OF C.E.T. FIRE PUMPS MFG.
ALL REPRODUCTION WITHOUT WRITTEN
AGREEMENT FROM C.E.T. FIRE PUMPS MFG
IS TOTALLY PROHIBITED.

REV.	DESCRIPTION	DATE	BY
A	Version A	01-01-16	M.P.

NO	PART NUMBER	DESCRIPTION	QTY
1	002-PP1-302	FLANGE 2-1/2"	1
2	005-PP1-012	FIRE GRADE VALVE 2"	1
3	022-PP1-003	HEX. BOLT 3/8"-16 x 1"	5
4	022-PP1-004	HEX. BOLT 3/8"-16 x 1-1/4"	3
5	034-PP1-014	MANOMETER 0-200	1
6	045-PP1-086	DRAIN VALVE 1/4" NPT-M	1
7	PO-0011-2102	PUMP END ASSEMBLY	1

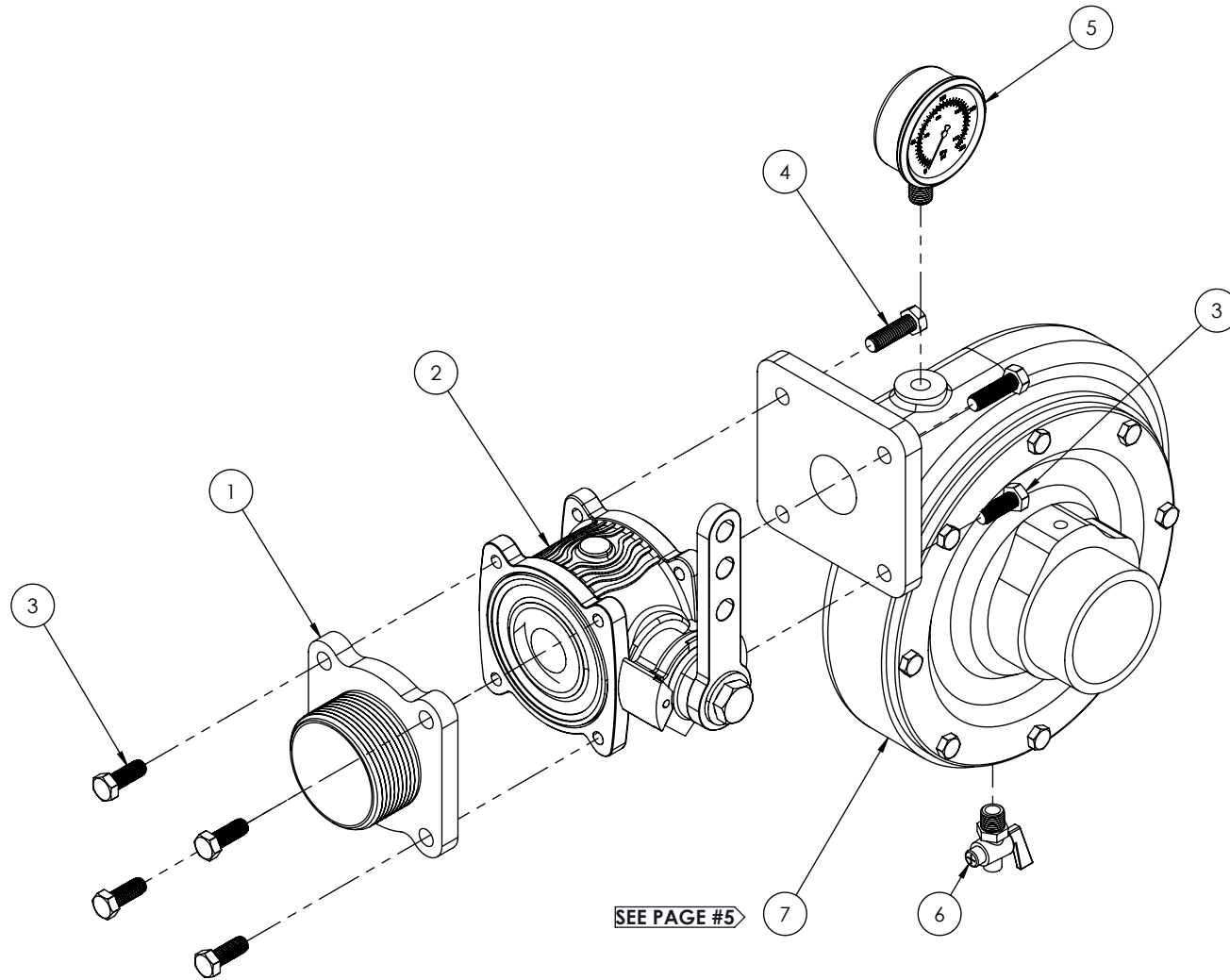

SEE PAGE #5



nqa.
ISO 9001
Registered
Quality
Management

CREATED
BY: M.P.
DATE: 02-09-16
VERIFIED
BY: M.P.
DATE: 02-09-16

TITLE : PUMP END ACCESSORIES ASSEMBLY
11hp Honda M - 11
No: **PO-2511-0801**

WARNING

THIS DOCUMENT REMAINS THE PROPERTY OF C.E.T. FIRE PUMPS MFG.
ALL REPRODUCTION WITHOUT WRITTEN AGREEMENT FROM C.E.T. FIRE PUMPS MFG IS TOTALLY PROHIBITED.

A	Version A	01-01-16	M.P.
REV.	DESCRIPTION	DATE	BY

NO	PART NUMBER	DESCRIPTION	QTY
1	020-PP1-002	MECHANICAL SEAL 1-1/4" (SS)	1
2	022-PP1-401	HEX. BOLT 5/16"-24 x 2-1/4" (SS)	4
3	022-PP1-403	HEX. BOLT 5/16"-18 x 1" (SS)	8
4	022-PP1-420	HEX. BOLT 3/8"-24 x 1-1/4" (SS)	1
5	052-PP1-262	O-RING	1
6	060-PP1-051	CAP 11hp (BRASS)	1
7	060-PP1-083	BUSHING	1
8	PO-0000-2304	COVER	1
9	PO-0000-2405	IMPELLER	1
10	PO-0011-2201	CASING	1

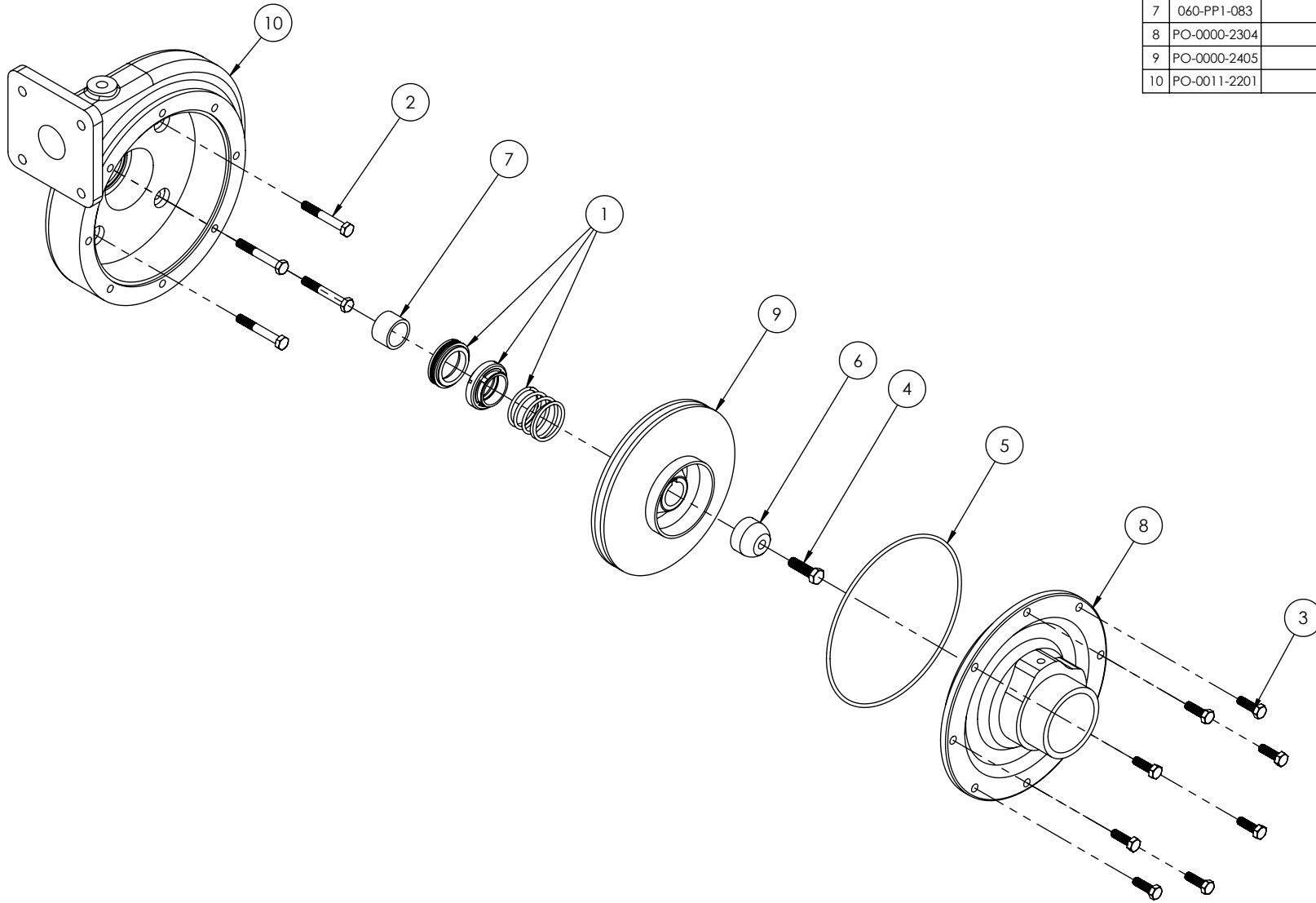

nqa.
ISO 9001
Registered
Quality
Management

CREATED
BY: M.P.
DATE: 26-08-16
VERIFIED
BY: M.P.
DATE: 26-08-16

TITLE : PUMP END ASSEMBLY
11hp Honda - 11
No: PO-0011-2102

WARNING

THIS DOCUMENT REMAINS THE PROPERTY OF C.E.T. FIRE PUMPS MFG.
ALL REPRODUCTION WITHOUT WRITTEN AGREEMENT FROM C.E.T. FIRE PUMPS MFG IS TOTALLY PROHIBITED.

A	Version A	01-01-16	M.P.
REV.	DESCRIPTION	DATE	BY