

PORTABLE FIRE PUMP
PFP-6hpHND-EM-TWIN
GX200 HONDA WITH HIGH-PRESSURE PUMP

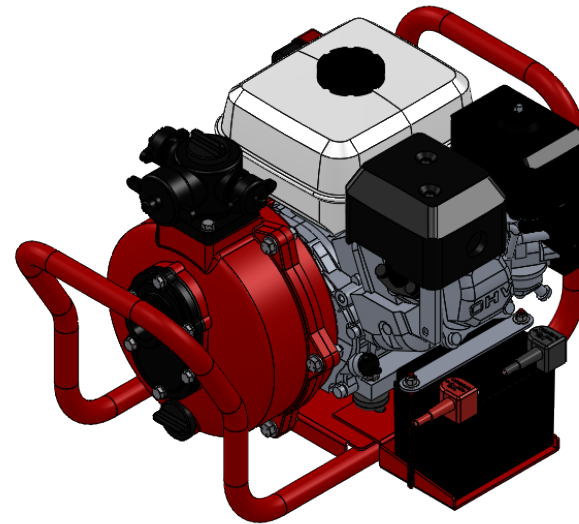

WE CAN CUSTOMIZE AS YOU WANT

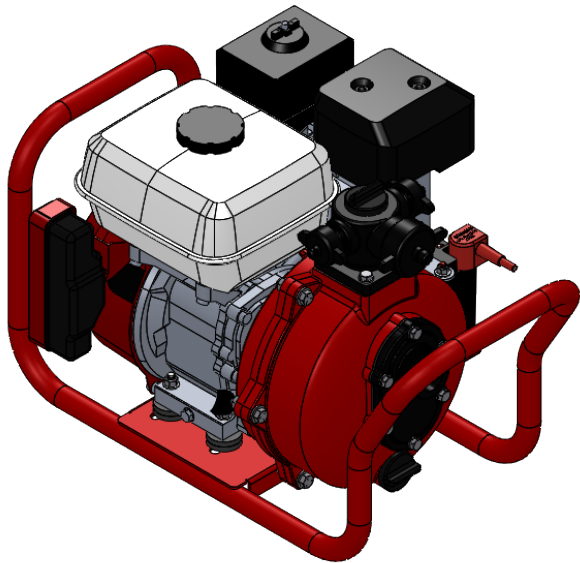
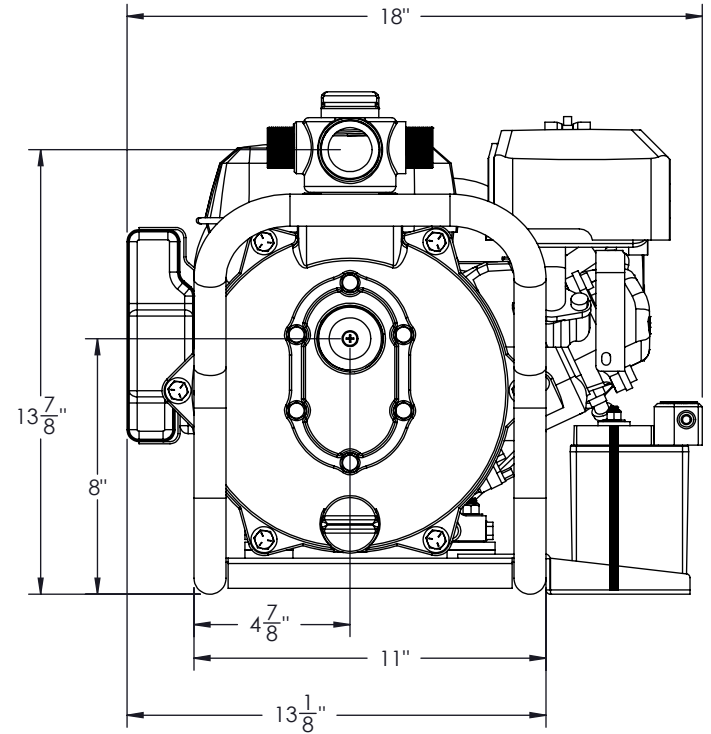
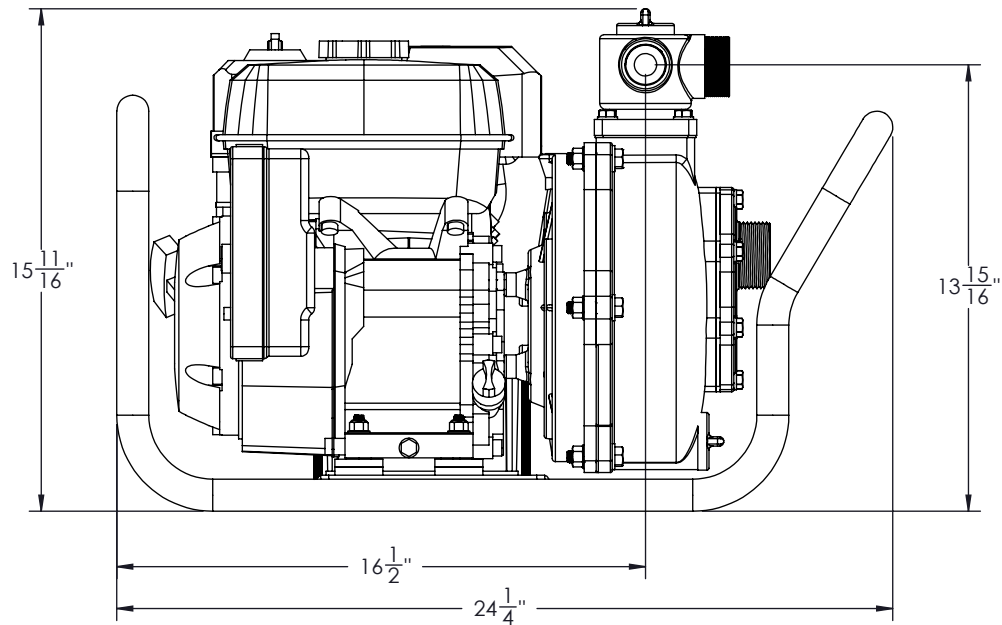

WET WEIGHT: 95lbs

	CREATED BY: M.V. DATE: 08-01-15	TITLE : PFP-6hpHND-EM-TWIN HALF FRAME	WARNING THIS DOCUMENT REMAINS THE PROPERTY OF C.E.T. FIRE PUMPS MFG. ALL REPRODUCTION WITHOUT WRITTEN AGREEMENT FROM C.E.T. FIRE PUMPS MFG IS TOTALLY PROHIBITED.
	VERIFIED BY: M.P. DATE: 03-11-15	No: PO-03TW-0703-A	

A	Version A	01-01-16	M.P.
REV.	DESCRIPTION	DATE	BY

NO	PART NUMBER	DESCRIPTION	QTY
1	001-PP1-006	HONDA ENGINE (GX200), ELECTRIC/MANUAL 6.5hp GAS	1
2	003-PP1-105	AIR FILTER	1
3	003-PP1-150	AIR FILTER FOAM	1
4	020-PP1-008	BATTERY FOAM TAPE 1/2' x 3"	3
5	022-PP1-016	HEX BOLT 5/16"-18 x 2"	4
6	023-PP1-005	HEX. NYLON LOCK NUT 5/16"-18	4
7	023-PP1-006	HEX. NYLON LOCKNUT 1/4"-20	2
8	024-PP1-004	FLAT WASHER 5/16" ID x 3/4" OD	6
9	025-PP1-015	RUBBER WASHER 0.312" INT x 1.5" EXT. x 1/4" TK	8
10	040-PP1-014	BATTERY CABLE CET-N-8.25	1
11	040-PP1-015B	BATTERY CABLE CET-R-10	1
12	040-PP1-075	BATTERY 12v	1
13	057-PP1-267A	BATTERY RETAINER PLATE	1
14	PO-0000-1724	HALF FRAME	1
15	PO-0000-9401	BATTERY SUPPORT	1
16	PO-00TW-2101	GOLIATH PUMP	1

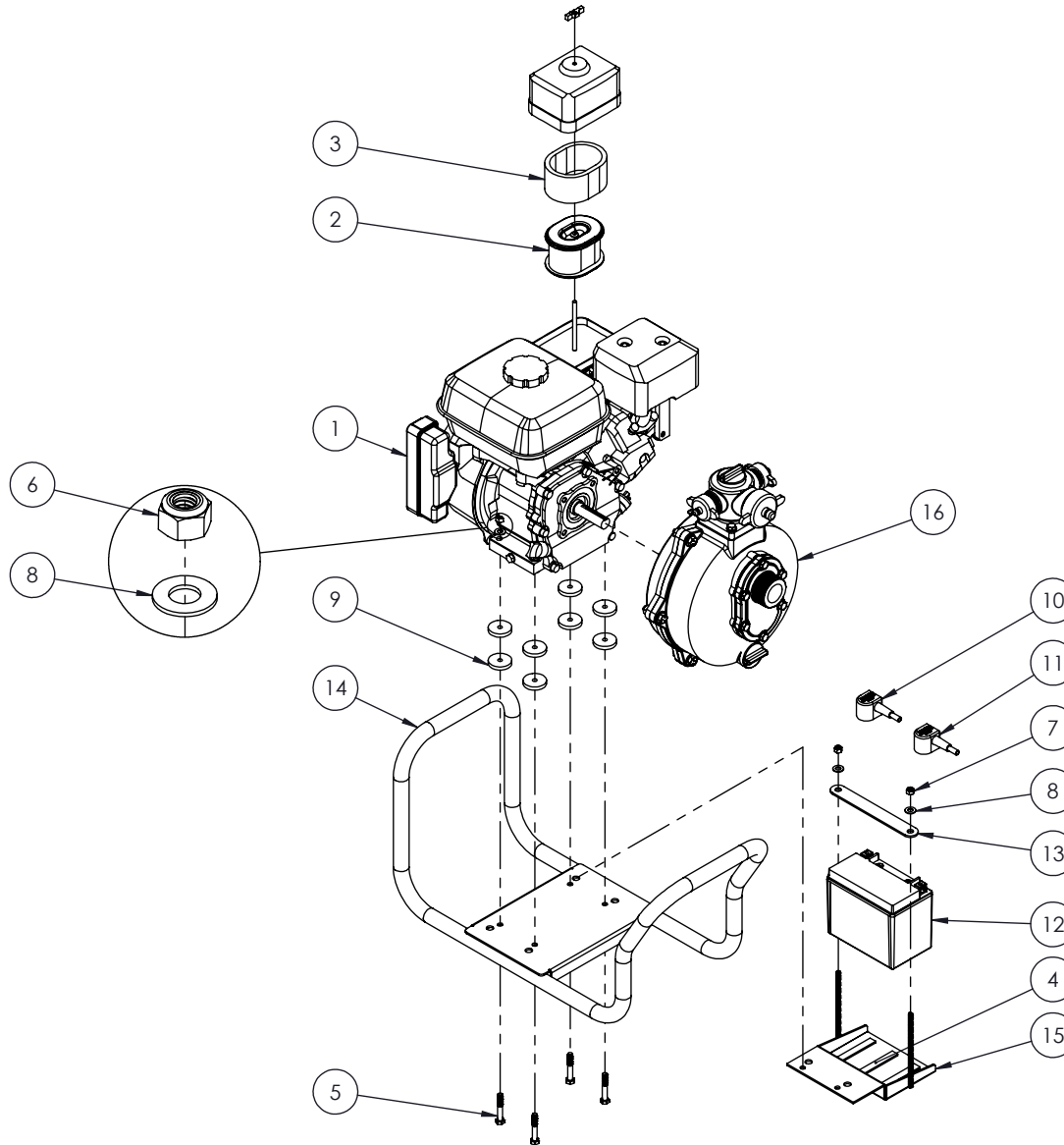

CREATED	TITLE : PFP-6hpHND-EM-TWIN
BY: M.V.	HALF FRAME
DATE: 08-01-15	
VERIFIED	No: PO-03TW-0703-A
BY: M.P.	
DATE: 03-11-15	

WARNING

THIS DOCUMENT REMAINS THE PROPERTY OF C.E.T. FIRE PUMPS MFG.

ALL REPRODUCTION WITHOUT WRITTEN AGREEMENT FROM C.E.T. FIRE PUMPS MFG IS TOTALLY PROHIBITED.

A	Version A	01-01-16	M.P.
REV.	DESCRIPTION	DATE	BY

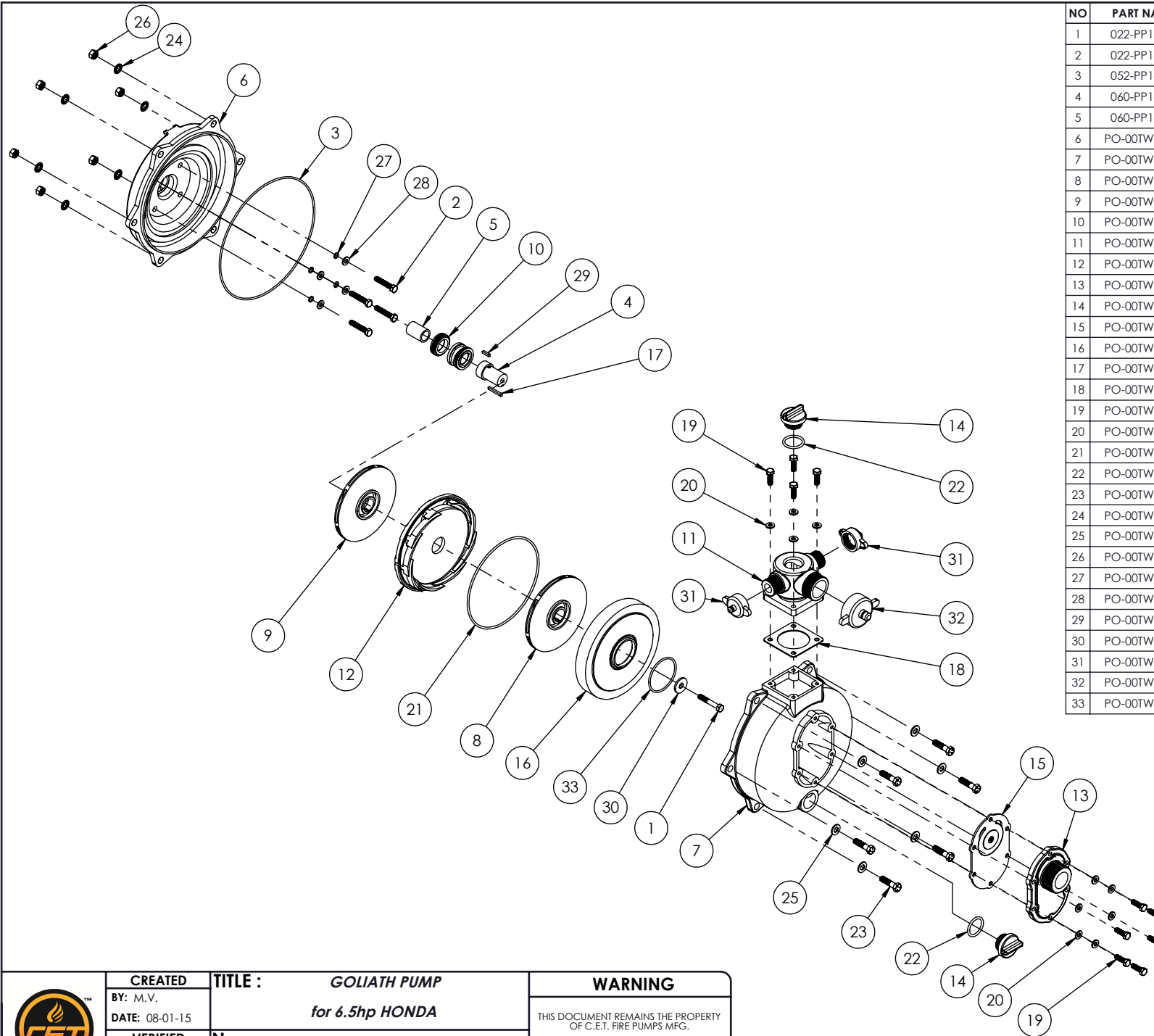

NO	PART NAME	DESCRIPTION	QTY
1	022-PP1-414	HEX. BOLT 5/16"-24 x 2" (SS)	1
2	022-PP1-427	HEX. BOLT 5/16"-24 x 1-3/4" (SS)	4
3	052-PP1-001	O-RING	1
4	060-PP1-061	SHAFT EXTENSION	1
5	060-PP1-084	BUSHING	1
6	PO-00TW-2201	CASING	1
7	PO-00TW-2301	COVER	1
8	PO-00TW-2401	FRONT IMPELLER	1
9	PO-00TW-2402	REAR IMPELLER	1
10	PO-00TW-2701	MECHANICAL SEAL	1
11	PO-00TW-2702	MANIFOLD	1
12	PO-00TW-2703	STATOR	1
13	PO-00TW-2801	INTAKE	1
14	PO-00TW-2802	PLUG	2
15	PO-00TW-2803	INTAKE GASKET	1
16	PO-00TW-2804	HIGH PRESSURE IMPELLER COVER	1
17	PO-00TW-2806	IMPELLER KEY	1
18	PO-00TW-2807	MANIFOLD GASKET	1
19	PO-00TW-2808	HEX. BOLT	10
20	PO-00TW-2809	WASHER	10
21	PO-00TW-2810	O-RING	1
22	PO-00TW-2811	O-RING	2
23	PO-00TW-2813	HEX. BOLT	6
24	PO-00TW-2814	INTERNAL LOCK WASHER	6
25	PO-00TW-2815	WASHER	6
26	PO-00TW-2816	HEX. NUT	6
27	PO-00TW-2817	O-RING	4
28	PO-00TW-2818	WASHER	4
29	PO-00TW-2820	SHAFT KEY	1
30	PO-00TW-2822	WASHER	1
31	PO-00TW-2824	1" CAP	2
32	PO-00TW-2825	1-1/2" CAP	1
33	PO-00TW-2826	O-RING	1



CREATED	TITLE :	GOLIATH PUMP
BY: M.V.		for 6.5hp HONDA
DATE: 08-01-15		
VERIFIED	No:	PO-00TW-2101
BY: M.P.		
DATE: 02-11-15		

WARNING

THIS DOCUMENT REMAINS THE PROPERTY OF C.E.T. FIRE PUMPS MFG.

ALL REPRODUCTION WITHOUT WRITTEN AGREEMENT FROM C.E.T. FIRE PUMPS MFG IS TOTALLY PROHIBITED.

A	Version A	01-01-16	M.P.
REV.	DESCRIPTION	DATE	BY