

**PORTABLE FIRE PUMP**  
**PFP-9hpHND-EM**  
**GX270 HONDA WITH HIGH-VOLUME PUMP**

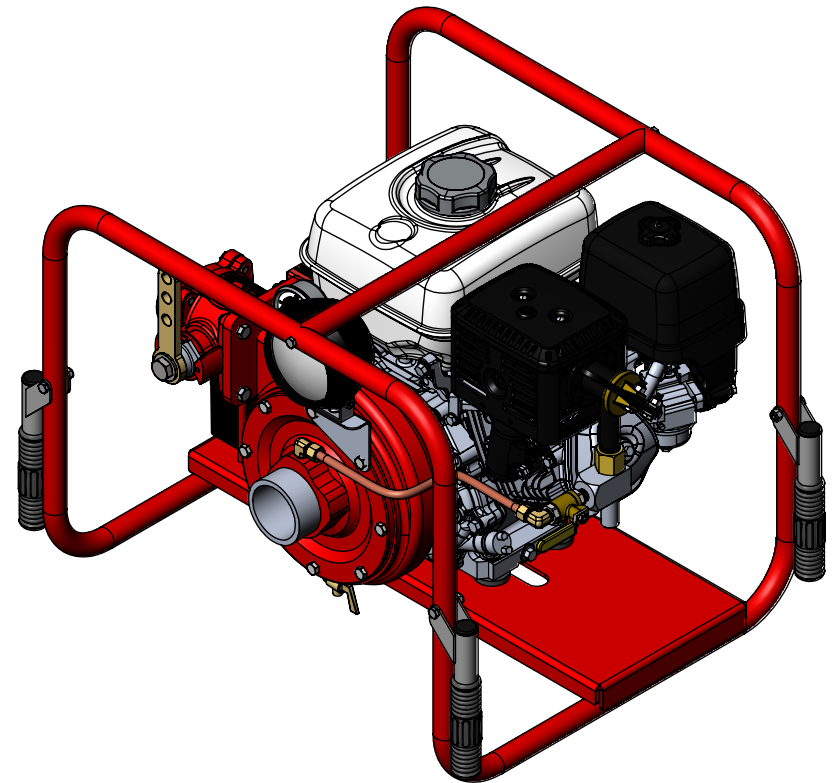

**WE CAN CUSTOMIZE AS YOU WANT**

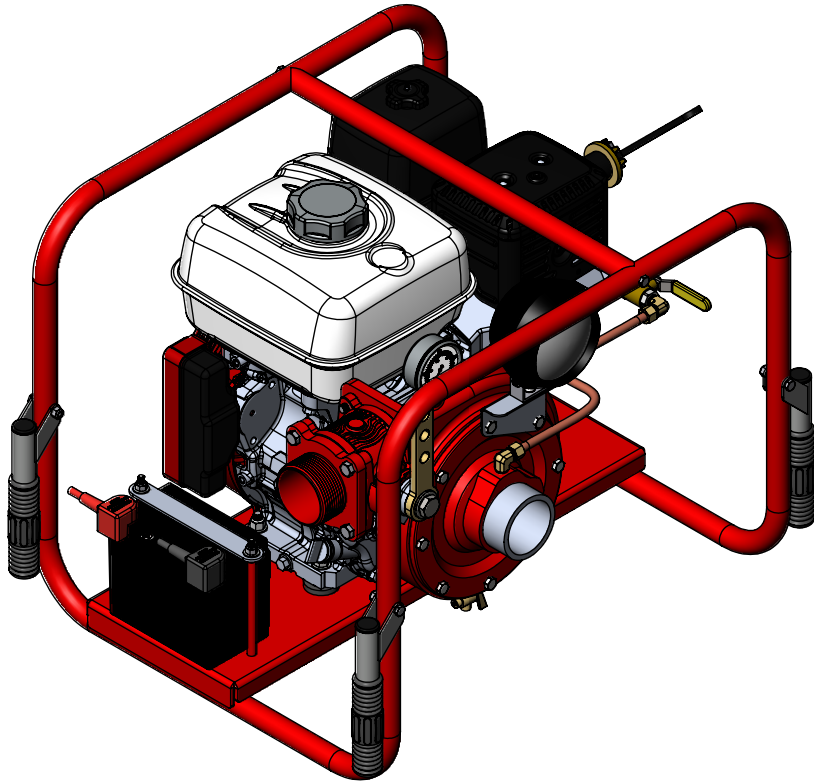
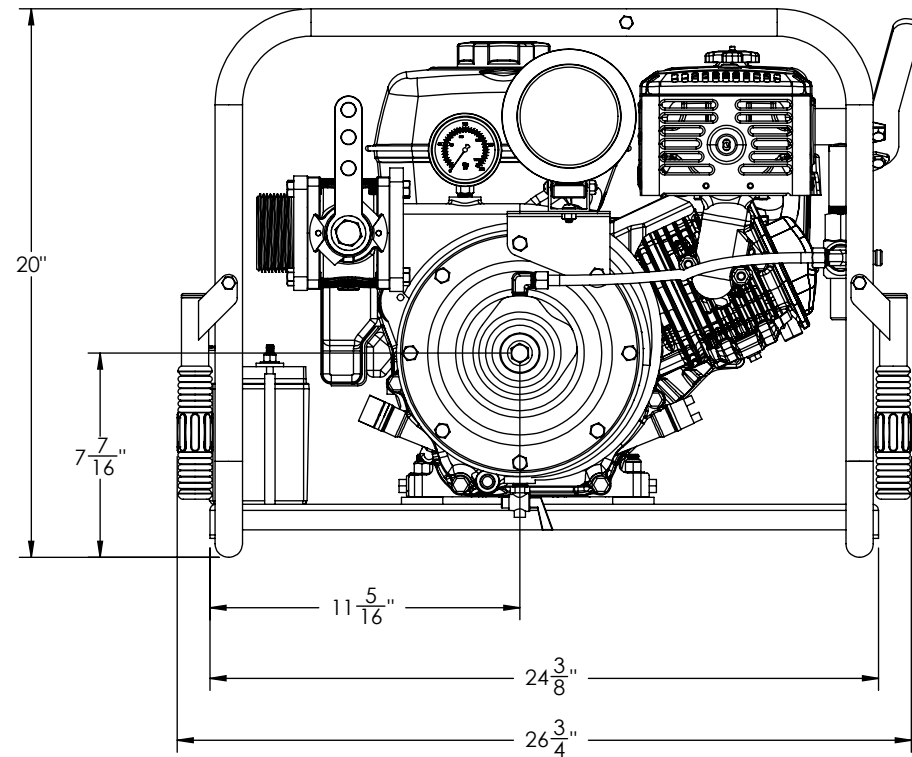
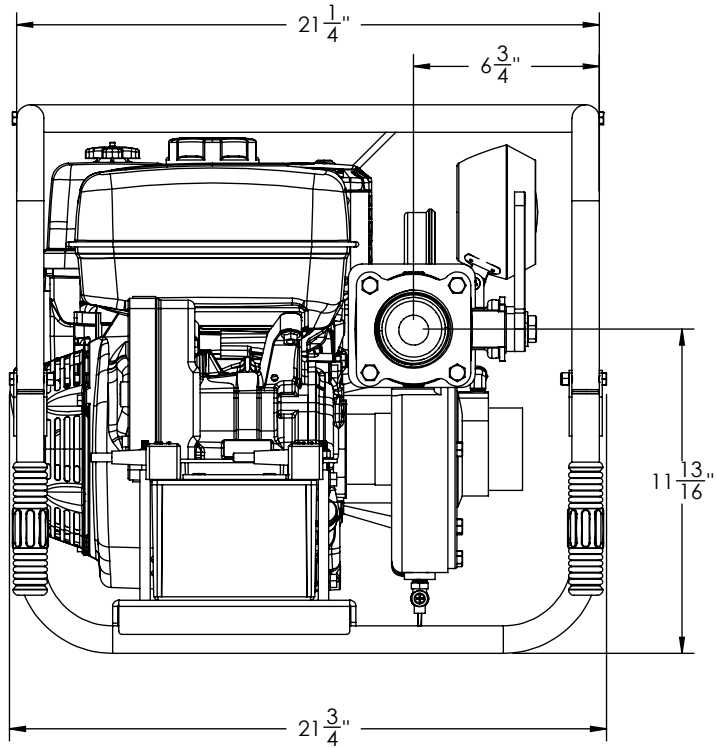

**WET WEIGHT: 115 lbs**



**nqa.**  
ISO 9001  
Registered  
Quality  
Management

**CREATED**  
BY: M.P.  
DATE: 29-08-16  
**VERIFIED**  
BY: M.P.  
DATE: 29-08-16

**TITLE :** PFP-9hpHND-EM  
FULL FRAME  
**No:** PO-0911-0701-A

**WARNING**

THIS DOCUMENT REMAINS THE PROPERTY OF C.E.T. FIRE PUMPS MFG.  
ALL REPRODUCTION WITHOUT WRITTEN AGREEMENT FROM C.E.T. FIRE PUMPS MFG IS TOTALLY PROHIBITED.

REV.	DESCRIPTION	DATE	BY
A	Version A	01-01-16	M.P.

NO	PART NUMBER	DESCRIPTION	QTY
1	001-PP1-004	HONDA ENGINE (GX270), ELECTRIC/MANUAL 9hp GAS	1
2	003-PP1-104	AIR FILTER	1
3	003-PP1-151	AIR FILTER FOAM	1
4	005-PP1-205	BALL VALVE 1/4" NPT-F	1
5	010-PP1-999	COPPER TUBE 3/8" x 13"	1
6	020-PP1-008	BATTERY FOAM TAPE 1/2" x 3"	3
7	022-PP1-009	HEX. BOLT 3/8"-16 x 2" (Gr.5 ZINC)	4
8	022-PP1-313	HEX. BOLT 1/4"-20 x 6"	2
9	023-PP1-001	HEX. NYLON LOCKNUT 3/8"-16	4
10	023-PP1-006	HEX. NYLON LOCKNUT 1/4"-20	2
11	024-PP1-004	FLAT WASHER 5/16" ID x 3/4"OD	2
12	024-PP1-009	FLAT WASHER 3/8" int. x 7/8" ext.	4
13	025-PP1-015	RUBBER WASHER 0.312" INT x 1.5" EXT. x 1/4" TK	4
14	040-PP1-005	TUBE for BATTERY ROD 1/4" x 4-3/4" RED	2
15	040-PP1-029	BATTERY CABLE (BLACK)	1
16	040-PP1-075	BATTERY 12v	1
17	040-PP1-543	BATTERY CABLE CET-R-10	1
18	045-PP1-112	CLOSE NIPPLE BRASS 1/4" NPT-M	1
19	045-PP1-132	COMP. 90° ELBOW 3/8" TUBE x 1/4" NPT-M	2
20	057-PP1-267A	BATTERY RETAINER PLATE	1
21	060-PP1-163	SHAFT KEY 1/4"	1
22	PO-0000-1712	FULL FRAME	1
23	PO-0000-4102	VENTURY	1
24	PO-0000-5721A	MUFFLER	1
25	PO-0000-6601	SMALL HANDLE	4
26	PO-0911-0801	PUMP END ACCESSORIES ASSEMBLY	1

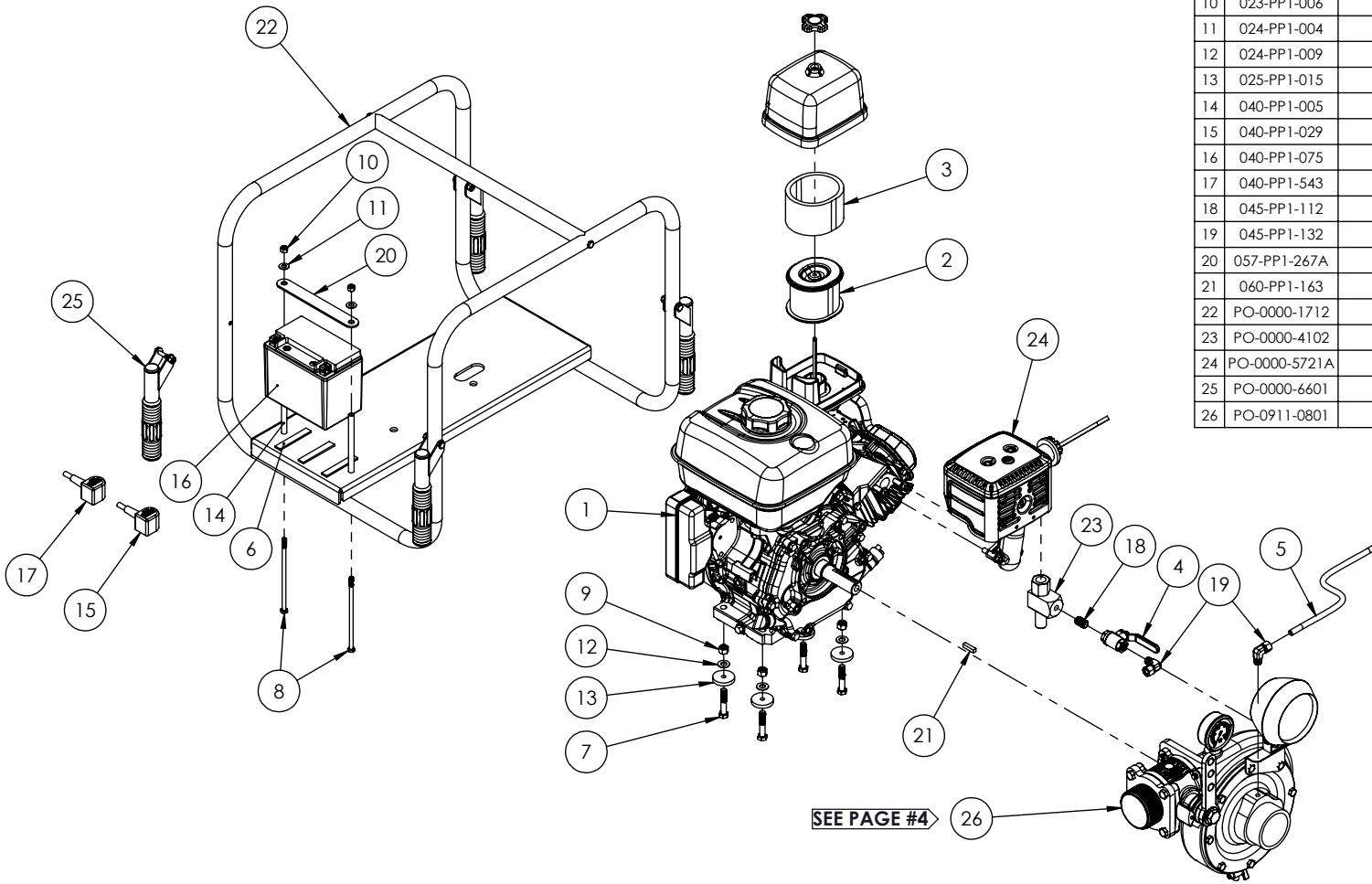

**CREATED**  
 BY: M.P.  
 DATE: 29-08-16  
**VERIFIED**  
 BY: M.P.  
 DATE: 29-08-16

**TITLE :** PFP-9hpHND-EM  
 FULL FRAME  
**No:** PO-0911-0701-A

**WARNING**  
 THIS DOCUMENT REMAINS THE PROPERTY OF C.E.T. FIRE PUMPS MFG.  
 ALL REPRODUCTION WITHOUT WRITTEN AGREEMENT FROM C.E.T. FIRE PUMPS MFG IS TOTALLY PROHIBITED.

A	Version A	01-01-16	M.P.
REV.	DESCRIPTION	DATE	BY

NO	PART NUMBER	DESCRIPTION	QTY
1	002-PP1-302	FLANGE 2-1/2" M	1
2	005-PP1-012	FIRE GRADE VALVE 2"	1
3	022-PP1-003	HEX. BOLT 3/8-16 x 1"	5
4	022-PP1-004	HEX. BOLT 3/8"-16 x 1-1/4"	3
5	034-PP1-014	MANOMETER 0-200	1
6	040-PP1-004	PAR36 LIGHT	1
7	045-PP1-086	DRAIN VALVE 1/4" NPT-M	1
8	057-PP1-045A	LIGHT BRACKET	1
9	PO-0011-2101	PUMP END ASSEMBLY	1

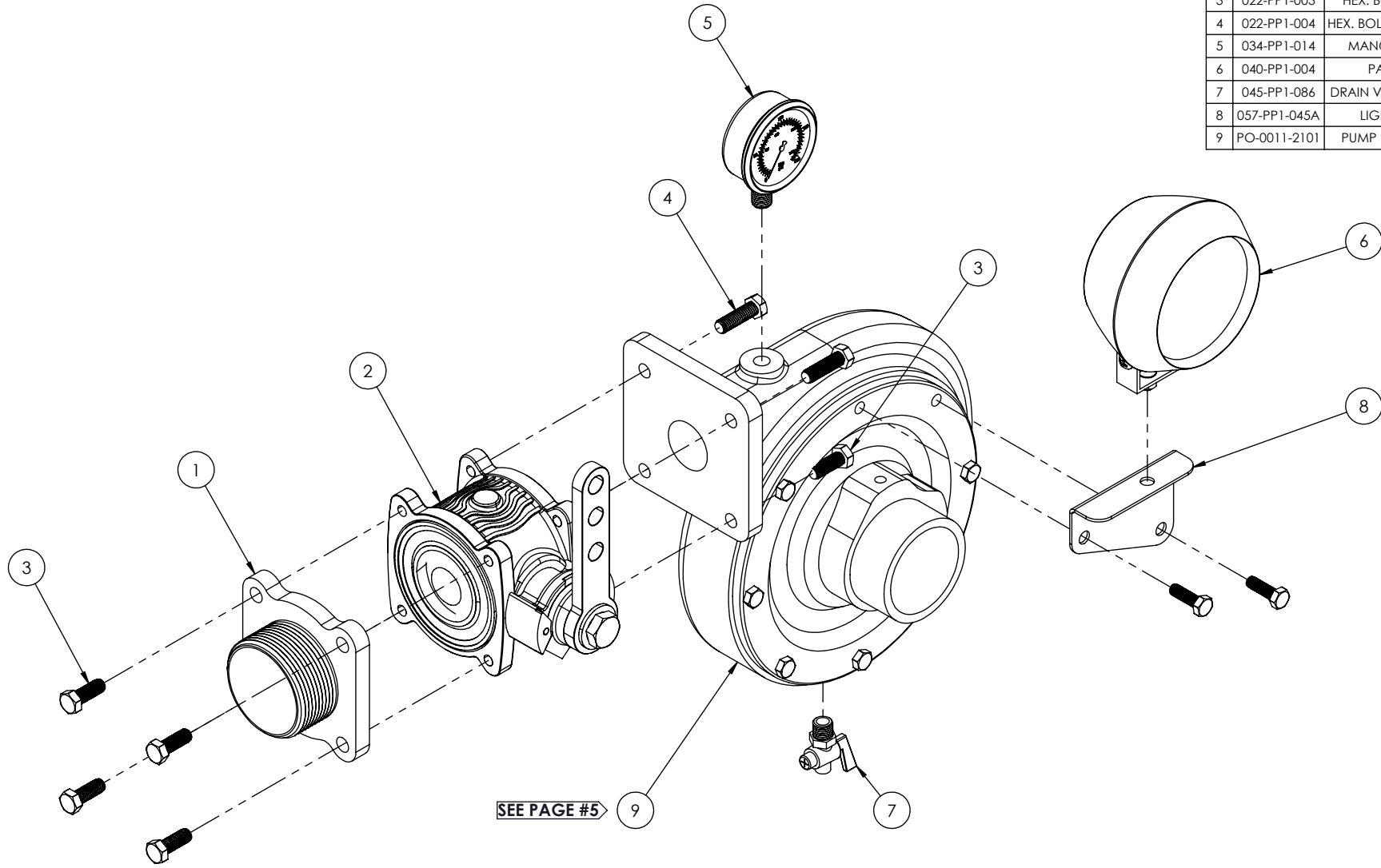

SEE PAGE #5



**CREATED**  
BY: M.P.  
DATE: 26-08-16

**VERIFIED**  
BY: M.P.  
DATE: 26-08-16

**TITLE : PUMP END ACCESSORIES ASSEMBLY**

*9hp Honda EM - 11*

**No: PO-0911-0801**

**WARNING**

THIS DOCUMENT REMAINS THE PROPERTY OF C.E.T. FIRE PUMPS MFG.

ALL REPRODUCTION WITHOUT WRITTEN AGREEMENT FROM C.E.T. FIRE PUMPS MFG IS TOTALLY PROHIBITED.

REV.	DESCRIPTION	DATE	BY
A	Version A	01-01-16	M.P.

NO	PART NUMBER	DESCRIPTION	QTY
1	020-PP1-002	MECHANICAL SEAL 1-1/4" (SS)	1
2	022-PP1-401	HEX. BOLT 5/16"-24 x 2-1/4" (SS)	4
3	022-PP1-403	HEX. BOLT 5/16"-18 x 1" (SS)	8
4	022-PP1-409	HEX. BOLT 7/16"-20 x 1-1/2" (SS)	1
5	052-PP1-262	O'RING	1
6	060-PP1-083	BUSHING	1
7	060-PP1-126A	CAP	1
8	PO-0000-2304	COVER	1
9	PO-0000-2405	IMPELLER	1
10	PO-0011-2201	CASING	1

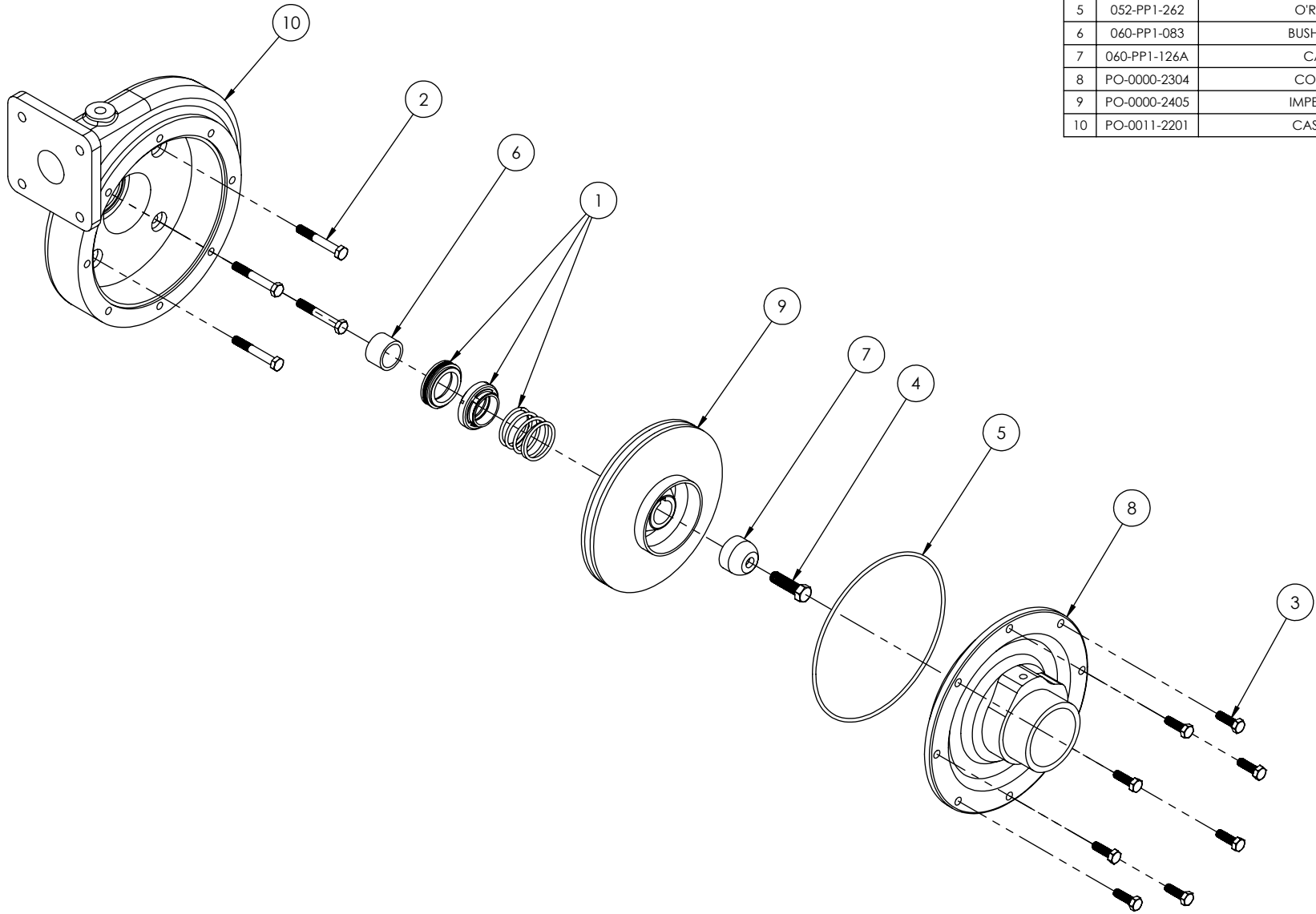

**CREATED**  
BY: M.P.  
DATE: 26-08-16

**VERIFIED**  
BY: M.P.  
DATE: 26-08-16

**TITLE :** PUMP END ASSEMBLY  
9hp Honda - 11

**No:** PO-0011-2101

**WARNING**

THIS DOCUMENT REMAINS THE PROPERTY OF C.E.T. FIRE PUMPS MFG.

ALL REPRODUCTION WITHOUT WRITTEN AGREEMENT FROM C.E.T. FIRE PUMPS MFG IS TOTALLY PROHIBITED.

A	Version A	01-01-16	M.P.
REV.	DESCRIPTION	DATE	BY