



ACCEPT ONLY THE BEST



GLIDER KIT

**A UNIVERSE
OF TECHNOLOGY**

Toll Free: 1-800-567-2719

www.fire-pump.com

*CET is a trademark of CET Fire Pumps Mfg, Ltd.

GLIDER KITS

CET offers quality and value with a unique Glider Kit program. Brush truck to Quick-Attack.

Engineered, manufactured and assembled for your convenience. A Glider Kit is composed of a CET drop-in, CET polypropylene or aluminum compartments and a CET custom heavy duty Fire Application flatbed.



ADVANTAGES OF A CET GLIDER KIT

- ▶ The Glider Kit package can be installed on a cab and chassis with supplied "U" bolts, Teflon "Dielectric" pads and brackets. This design allows the body and flatbed to withstand greater levels of stress that can distort other commercial style flat-beds. A truly "OFF ROAD" flatbed!
- ▶ A modular design allows removal from the chassis for major repair or mounting on a new chassis.
- ▶ The flatbed design offers unmatched, exclusive, CET features.
- ▶ Components are pre-assembled, pre-plumbed, pre-wired, and shipped to the OEM in a self-contained, tested unit.
- ▶ One manufacturer, one shipment to track, one service and warranty source.
- ▶ Quick delivery program.



GLIDER KIT SPECIFICATIONS

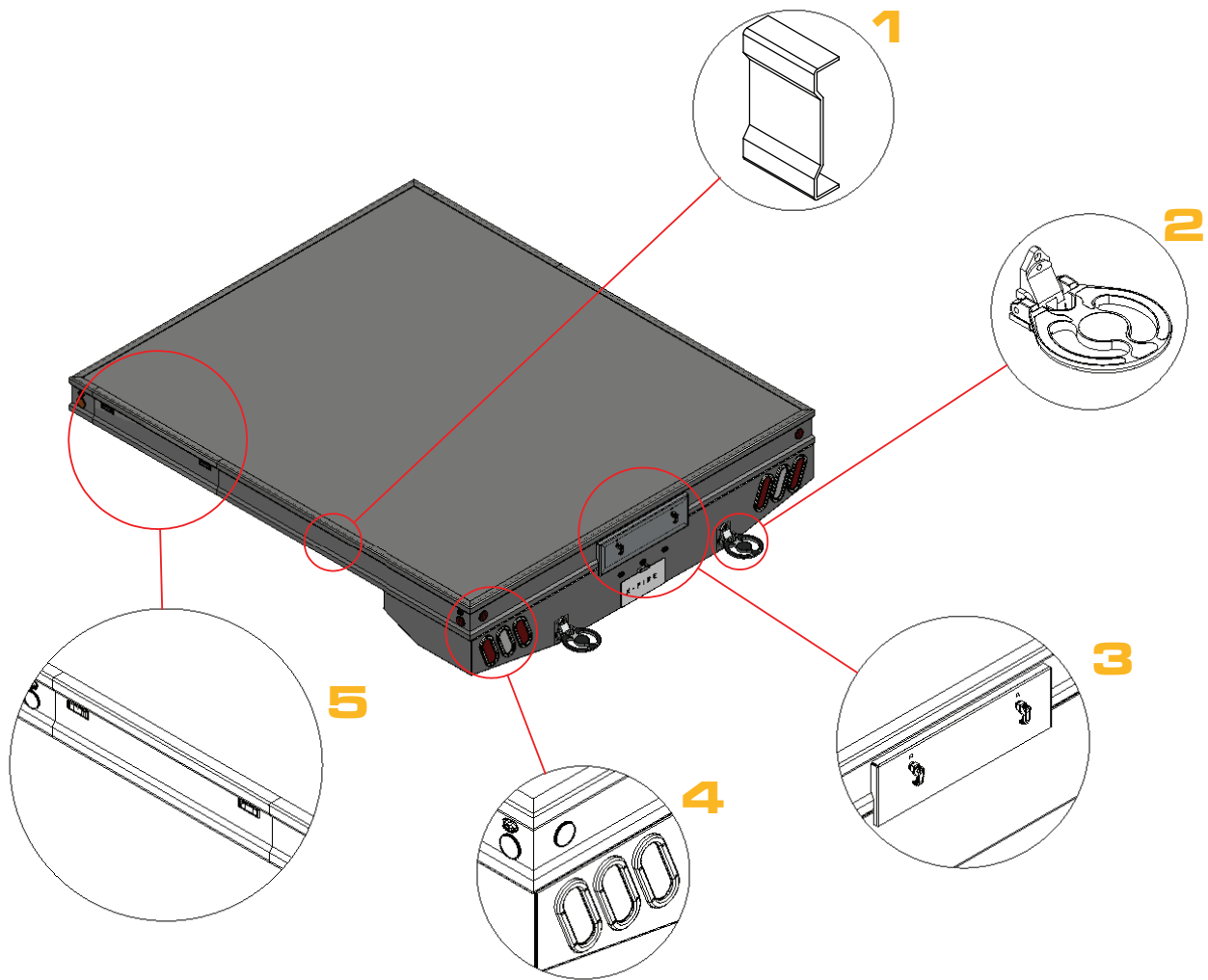

- 1** The perimeter is made from 1/8" thick forged 3003-H14 aluminum. Forged aluminum brings a strong design, made to imbed emergency lighting and a 4" reflective stripe.
- 2** Two non-skid rear steps for access to pump, controls and equipment are installed. The steps are rated for a minimum static load of 500 pounds, without deformation. NFPA 1906 and 1901 compliant.
- 3** Optional: Rear, integrated, full length compartment for suction hose, ladder or pike pole storage. A flip down door, horizontally hinged, shall be provided. The interior of the compartment shall be made from highly polished 3003-H14 smooth aluminum alloy plate.
- 4** Amber and red lights with reflectors are installed around the bed per D.O.T. requirements. LED signal, brake, and reverse lights with chrome housings are recess mounted in the rear aluminum shirt per FMVSS 108 and CMVSS 108 requirements.
- 5** Optional: Integrated pre-connected hose tray(s) with a flip down door made from aluminum. Capacity shall be a minimum of 250' of 1 3/4" DJ fire hose.

GLIDER KIT SPECIFICATIONS

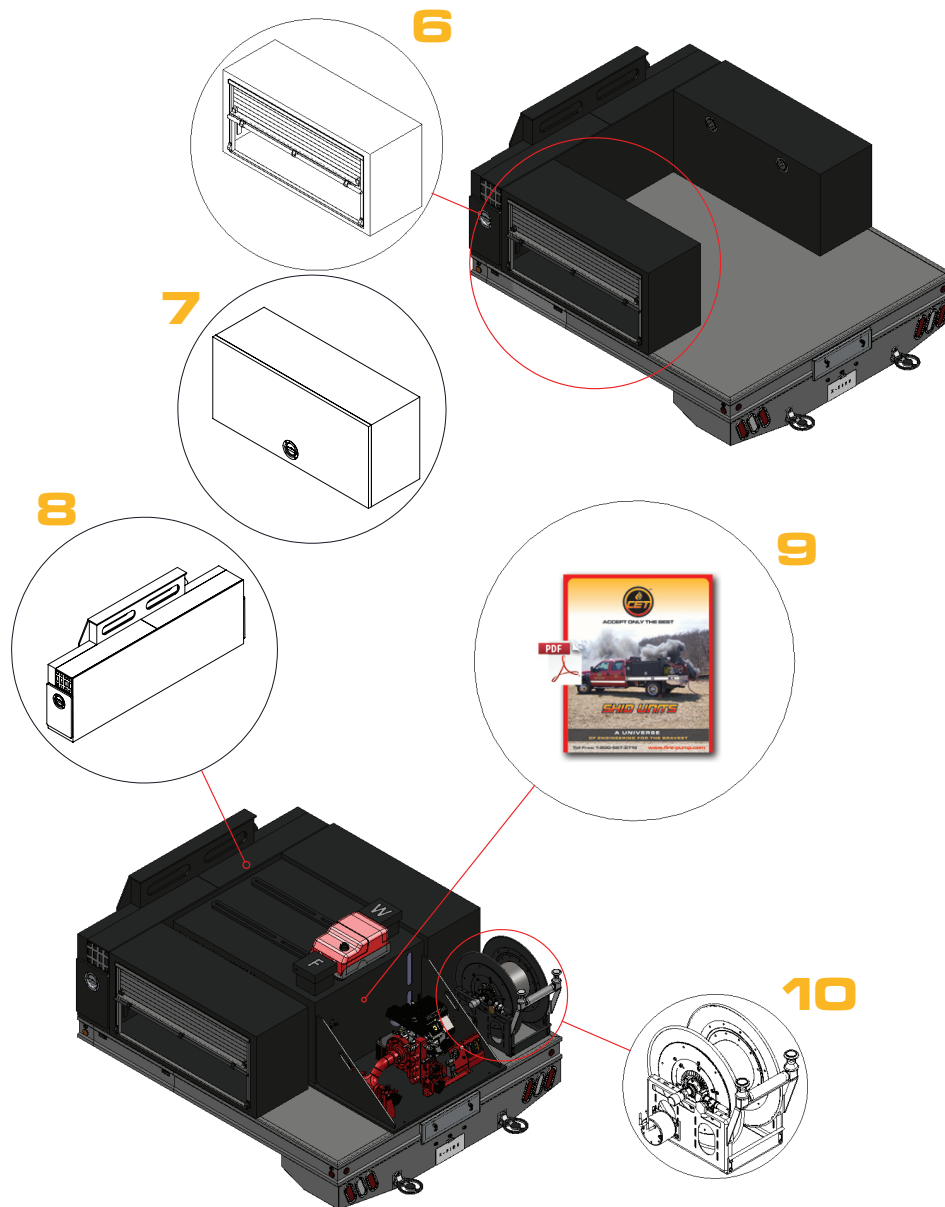

- 6** Polypropylene compartments are installed with roll-up doors, door ajar switches, and LED interior lights. Roll-up doors shall be gray anodized.
- 7** Optional: Aluminum Compartments can be substituted. Compartments are made from 1/8" aluminum tread plate sheet with horizontal or vertical hinged doors.
- 8** Optional: One transverse polypropylene or aluminum compartment with side doors, horizontally hinged, drop down with retaining cables. This custom compartment is designed to hold eight (8) shovels and eight (8) rakes. A fully enclosed hose storage tray can be installed on the top of the transverse compartment. Wet or dry.
- 9** Skid Unit. Please download our skid unit design aid and catalog at (www.fire-pump.com.)
- 10** Optional: Electric re-wind booster reel(s) with roller and guide assembly, can be installed on the side of the pump, at the rear of the truck bed and or on top of the tank.

GLIDER KIT SPECIFICATIONS

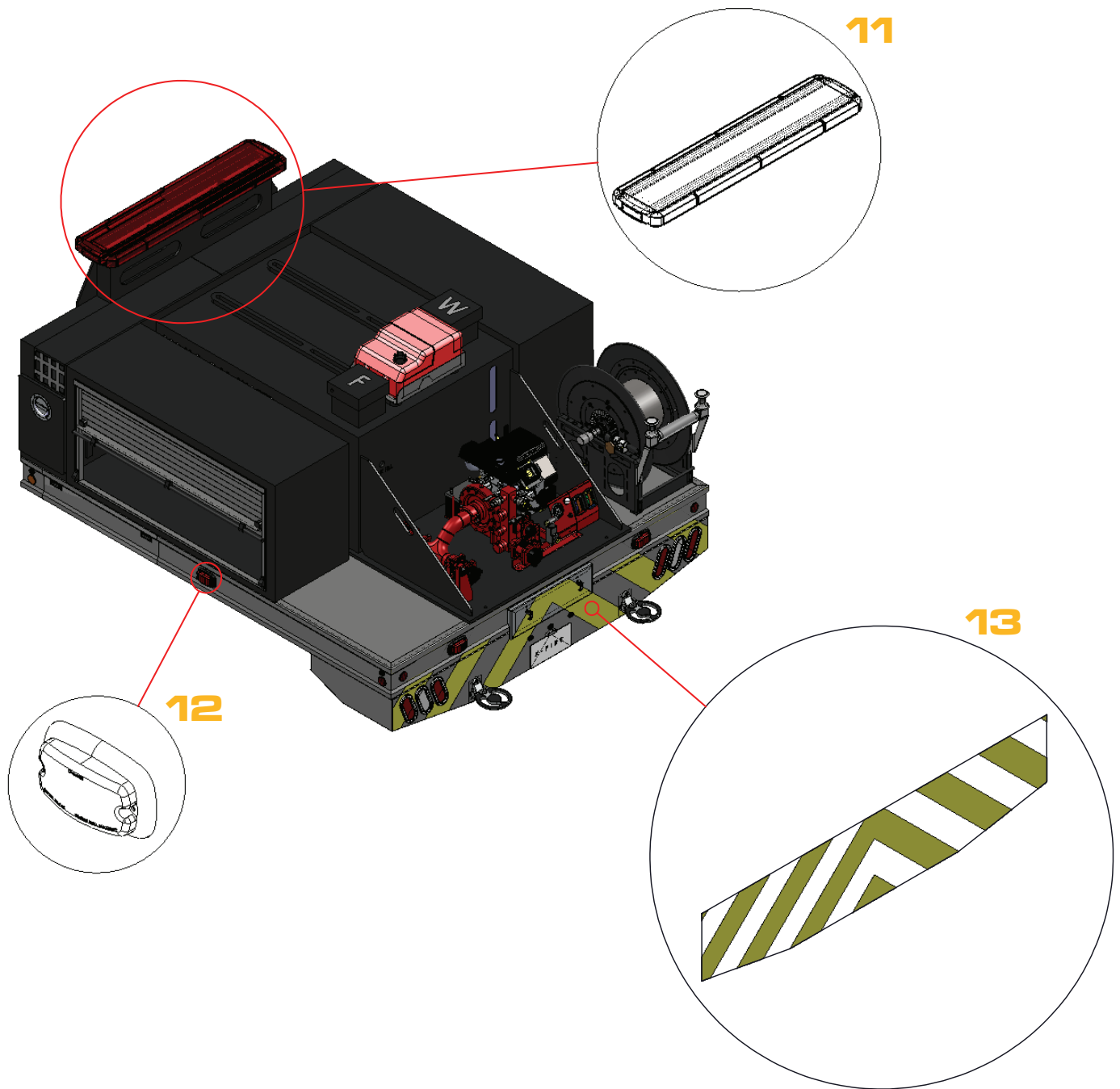

11 Optional: lightbar can be mounted on the top of the transverse compartment.

12 LED warning lights are mounted on the perimeter of the bed.

13 Optional: 6" red/yellow chevron stripes can be installed in the rear aluminum skirt.

GLIDER KIT SPECIFICATIONS

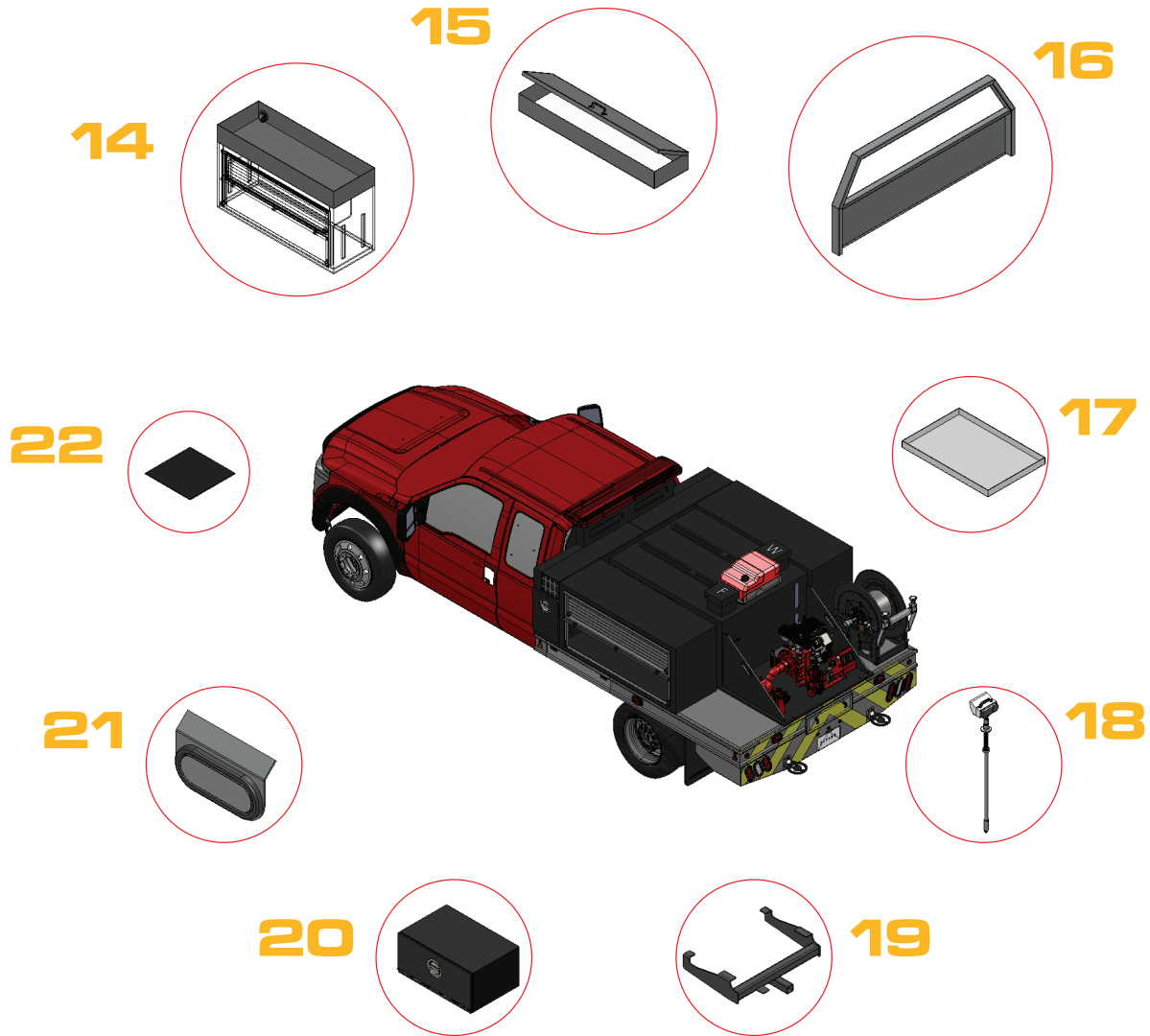

- 14** Optional: Pre-connect or storage trays made from polypropylene or aluminum can be installed on top of the side bed compartments. Red canvas covers with snaps can be installed on top of the storage trays along with rear protective netting.
- 15** Optional: Aluminum hinged lid(s) can be installed on the top of the storage tray(s).
- 16** Optional : Aluminum headache rack (Rear Cab Protection) with light bar platform and protective cross members can be installed.
- 17** Optional: Aluminum vertical adjustable shelf can be installed in the side compartments.
- 18** Optional: Telescopic scene lights can be installed at the front of the flatbed. The lights are fixed on the compartment or headache rack.
- 19** Optional: Rear mounted class III trailer hitch can be supplied. A 7 pin wiring, trailer, harness can be fixed at the rear of the flatbed.
- 20** Optional: Polypropylene or aluminum compartments located under the flatbed behind the cab, can be installed.
- 21** Optional: Ground lights can be installed.
- 22** Optional: Black plastic tiles can be installed to cover compartment floors.

GLIDER KIT

OUR MOST POPULAR MODELS

GLIDER KIT - 1

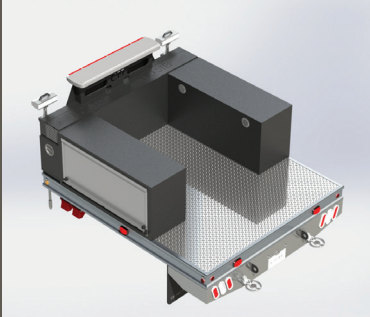

GLIDER KIT - 2

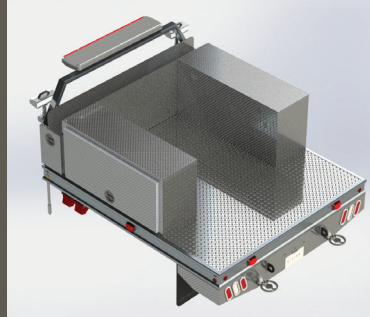

Standard flat bed and compartments

GLIDER KIT - 3



GLIDER KIT - 4

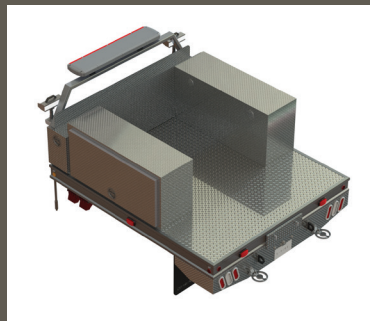

Standard flat bed with compartments and rear storage compartment

GLIDER KIT - 5



GLIDER KIT - 6

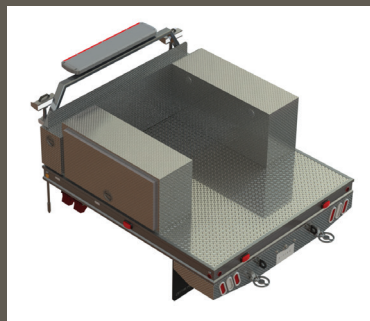

Standard flat bed with compartments and integrated pre-connect compartment on each side

GLIDER KIT - 7



GLIDER KIT - 8

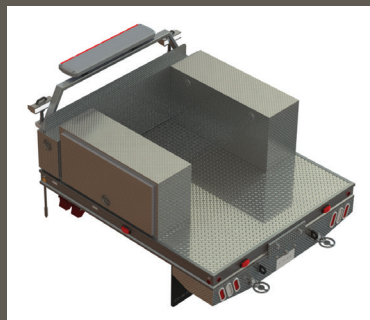

Standard flat bed with compartments, rear storage compartment and integrated pre-connect compartment on each side

Visit our website to download all the drawings and the specs sheets : www.fire-pump.com/gliderkit.html

GLIDER KIT INSTALLED ON YOUR SUPPLIED CHASSIS



A Universe of Solutions



Fire Truck



Glider Kit



Foam Trailer



Dual Totes Foam Trailer

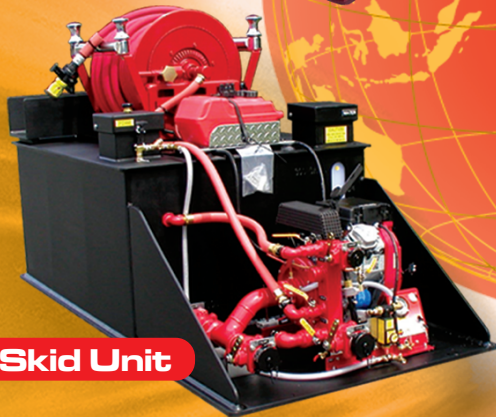

Skid Unit



Portable Pump



CAFS



ACCEPT ONLY THE BEST



Head office

75 Hector Street, P.O. Box 90
Pierreville, Qc, Canada J0G 1J0
Phone: 1-450-568-2719
Fax: 1-450-568-2613
E-mail: sales@fire-pump.com

US sales

Phone: 1-800-567-2719
Fax: 1-800-434-2613

www.fire-pump.com

A CENTURY OF ENGINEERING FOR THE BRAVEST

USA – CANADA – SOUTH AMERICA – EUROPE – ASIA / MIDDLE EAST

*CET is a trademark of CET Fire Pumps Mfg, Ltd.