

PORTABLE FIRE PUMP
PFP-20hpHND-MR
GX630 HONDA WITH MID-RANGE PUMP

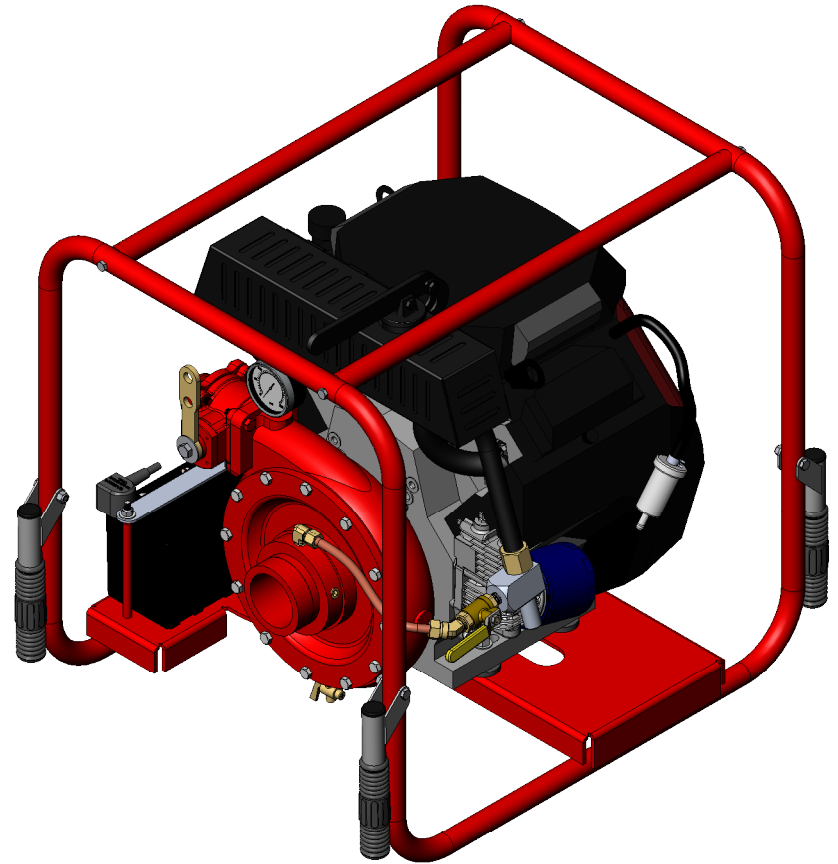

WE CAN CUSTOMIZE AS YOU WANT

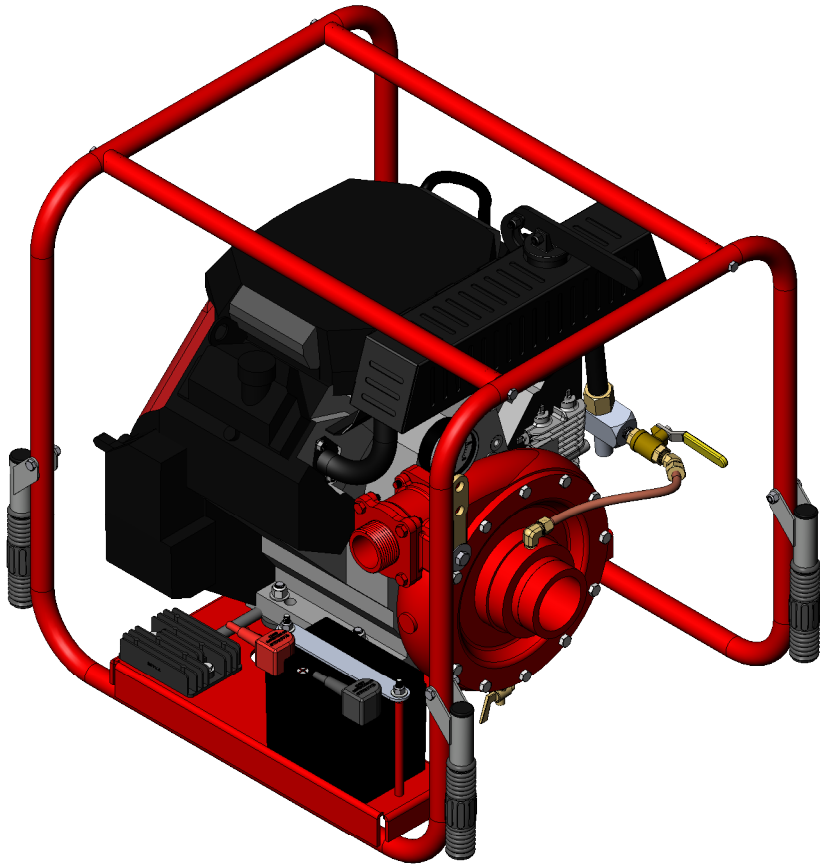
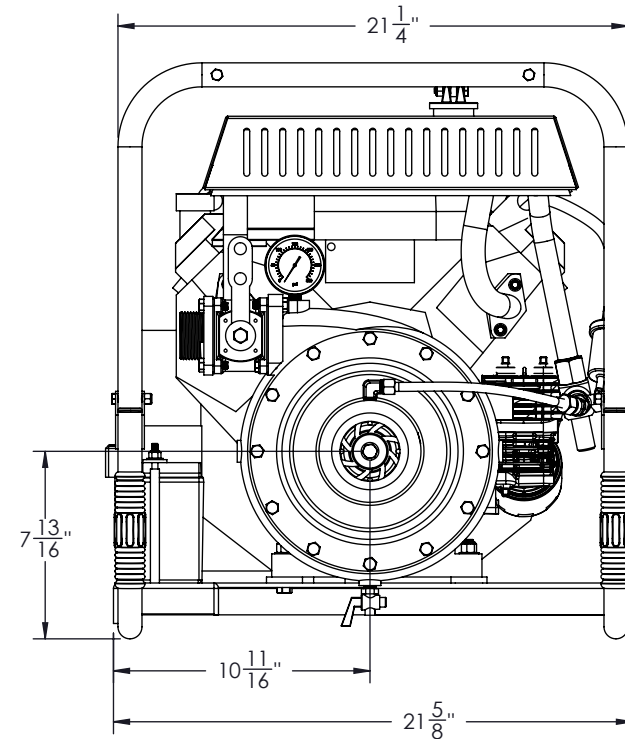
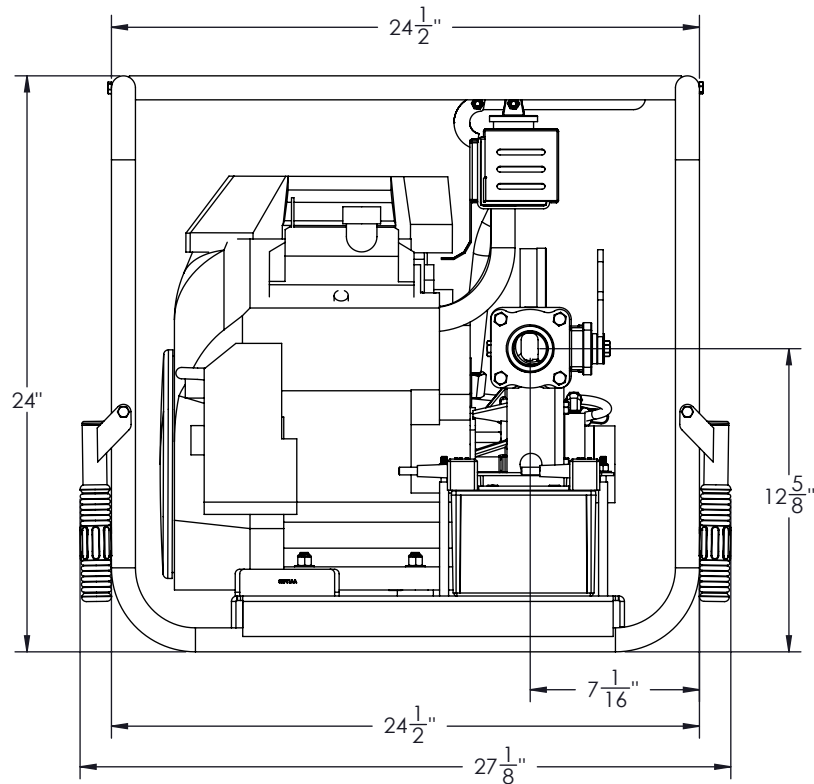

WET WEIGHT: 190lbs



nqa.
ISO 9001
Registered
Quality
Management

CREATED
BY: M.V.
DATE: 22-08-16
VERIFIED
BY: M.P.
DATE: 22-08-16

TITLE : PFP-20hpHND-MR
FULL FRAME
No: PO-42MR-0701-A

WARNING

THIS DOCUMENT REMAINS THE PROPERTY OF C.E.T. FIRE PUMPS MFG.
ALL REPRODUCTION WITHOUT WRITTEN AGREEMENT FROM C.E.T. FIRE PUMPS MFG IS TOTALLY PROHIBITED.

A	Version A	01-01-16	M.P.
REV.	DESCRIPTION	DATE	BY

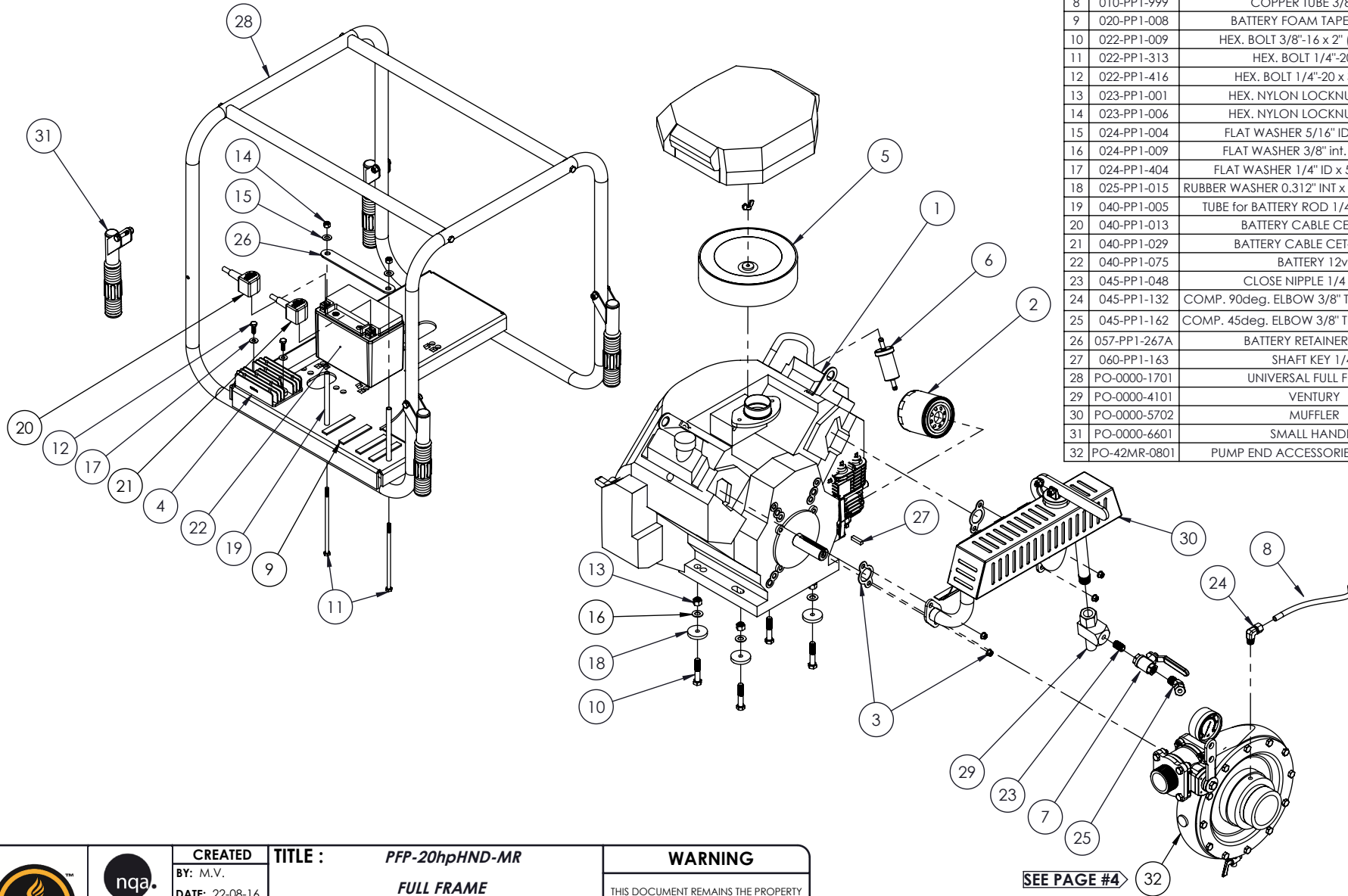

NO	PART NUMBER	DESCRIPTION	QTY
1	001-PP1-014	HONDA ENGINE, ELECTRIC 20hp V-TWIN	1
2	003-PP1-010	HONDA 18hp & 20hp OIL FILTER	1
3	003-PP1-017	GASKET MUFFLER KIT	1
4	003-PP1-094	HONDA VOLTAGE REGULATOR RECTIFIER	1
5	003-PP1-100	HONDA 20hp AIR FILTER	1
6	003-PP1-102	HONDA 20hp FUEL FILTER	1
7	005-PP1-205	BALL VALVE 1/4" NPT-F	1
8	010-PP1-999	COPPER TUBE 3/8" x 8"	1
9	020-PP1-008	BATTERY FOAM TAPE 1/2" x 3"	4
10	022-PP1-009	HEX. BOLT 3/8"-16 x 2" (Gr.5 ZINC)	4
11	022-PP1-313	HEX. BOLT 1/4"-20 x 6"	2
12	022-PP1-416	HEX. BOLT 1/4"-20 x 3/4" (SS)	2
13	023-PP1-001	HEX. NYLON LOCKNUT 3/8"-16	4
14	023-PP1-006	HEX. NYLON LOCKNUT 1/4"-20	2
15	024-PP1-004	FLAT WASHER 5/16" ID x 3/4"OD	2
16	024-PP1-009	FLAT WASHER 3/8" int. x 7/8" ext.	4
17	024-PP1-404	FLAT WASHER 1/4" ID x 5/8" OD (SS)	2
18	025-PP1-015	RUBBER WASHER 0.312" INT x 1.5" EXT. x 1/4" TK	4
19	040-PP1-005	TUBE for BATTERY ROD 1/4" x 4-3/4" RED	2
20	040-PP1-013	BATTERY CABLE CET-R-5LL	1
21	040-PP1-029	BATTERY CABLE CET-N-10.25	1
22	040-PP1-075	BATTERY 12v	1
23	045-PP1-048	CLOSE NIPPLE 1/4 NPT-M	1
24	045-PP1-132	COMP. 90deg. ELBOW 3/8" TUBE x 1/4" NPT-M	1
25	045-PP1-162	COMP. 45deg. ELBOW 3/8" TUBE x 1/4" NPT-M	1
26	057-PP1-267A	BATTERY RETAINER PLATE	1
27	060-PP1-163	SHAFT KEY 1/4"	1
28	PO-0000-1701	UNIVERSAL FULL FRAME	1
29	PO-0000-4101	VENTURY	1
30	PO-0000-5702	MUFFLER	1
31	PO-0000-6601	SMALL HANDLE	4
32	PO-42MR-0801	PUMP END ACCESSORIES ASSEMBLY	1

SEE PAGE #4



CREATED	TITLE :
BY: M.V.	PPF-20hpHND-MR
DATE: 22-08-16	FULL FRAME
VERIFIED	No:
BY: M.P.	PO-42MR-0701-A
DATE: 22-08-16	

WARNING	
THIS DOCUMENT REMAINS THE PROPERTY OF C.E.T. FIRE PUMPS MFG.	
ALL REPRODUCTION WITHOUT WRITTEN AGREEMENT FROM C.E.T. FIRE PUMPS MFG IS TOTALLY PROHIBITED.	
REV.	DESCRIPTION
A	Version A

01-01-16	M.P.
DATE	BY

NO	PART NUMBER	DESCRIPTION	QTY
1	002-PP1-301	FLANGE 1-1/2"	1
2	005-PP1-016	FIRE GRADE VALVE 1-1/2"	1
3	022-PP1-011	HEX. BOLT 5/16"-18 x 1"	4
4	022-PP1-031	HEX. BOLT 5/16"-18 x 1-1/4"	3
5	022-PP1-006	HEX. BOLT 1/4"-20 x 3/4"	1
6	034-PP1-020	DRY GAUGE 0/300psi DIA 2" x 1/4CMB	1
7	040-PP1-004	PAR36 LIGHT	1
8	045-PP1-086	DRAIN VALVE 1/4" NPT-M	1
9	045-PP1-101	PLUG HEX COUNTERSUNK 1/4" NPT-M	1
10	057-PP1-029	LIGHT BRACKET	1
11	PO-42MR-2101	PUMP END ASSEMBLY	1

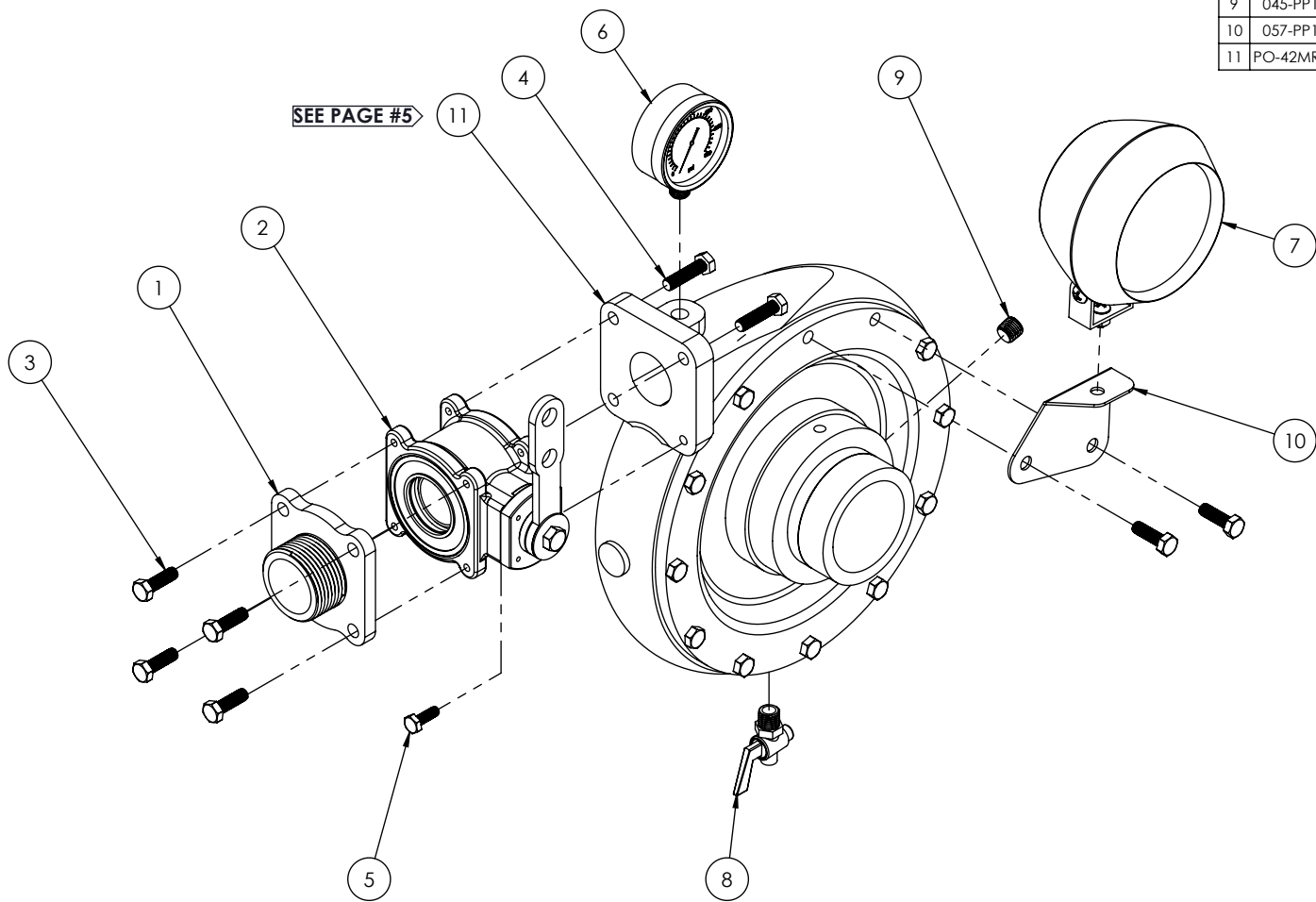

CREATED
 BY: M.V.
 DATE: 22-08-16
VERIFIED
 BY: M.P.
 DATE: 22-08-16

TITLE : PUMP END ACCESSORIES ASSEMBLY
PPF-20hpHND-MR
No: PO-42MR-0801

WARNING
 THIS DOCUMENT REMAINS THE PROPERTY OF C.E.T. FIRE PUMPS MFG.
 ALL REPRODUCTION WITHOUT WRITTEN AGREEMENT FROM C.E.T. FIRE PUMPS MFG IS TOTALLY PROHIBITED.

REV.	DESCRIPTION	DATE	BY
A	Version A	01-01-16	M.P.

NO	PART NUMBER	DESCRIPTION	QTY
1	002-PP1-012	IMPELLER MR	1
2	020-PP1-002	MECHANICAL SEAL 1-1/4" (SS)	1
3	022-PP1-401	HEX. BOLT 5/16"-24 x 2-1/4" (SS)	4
4	022-PP1-403	HEX. BOLT 5/16"-18 x 1" (SS)	12
5	022-PP1-420	HEX. BOLT 3/8"-24 x 1-1/4" (SS)	1
6	052-PP1-268	O'RING	1
7	060-PP1-050	CAP	1
8	060-PP1-069A	BUSHING	1
9	PO-0000-2301	COVER MR	1
10	PO-0000-2601	WATER RING COVER	1
11	PO-0000-2602	WATER RING CASING	1
12	PO-00MR-2201A	CASING MR	1

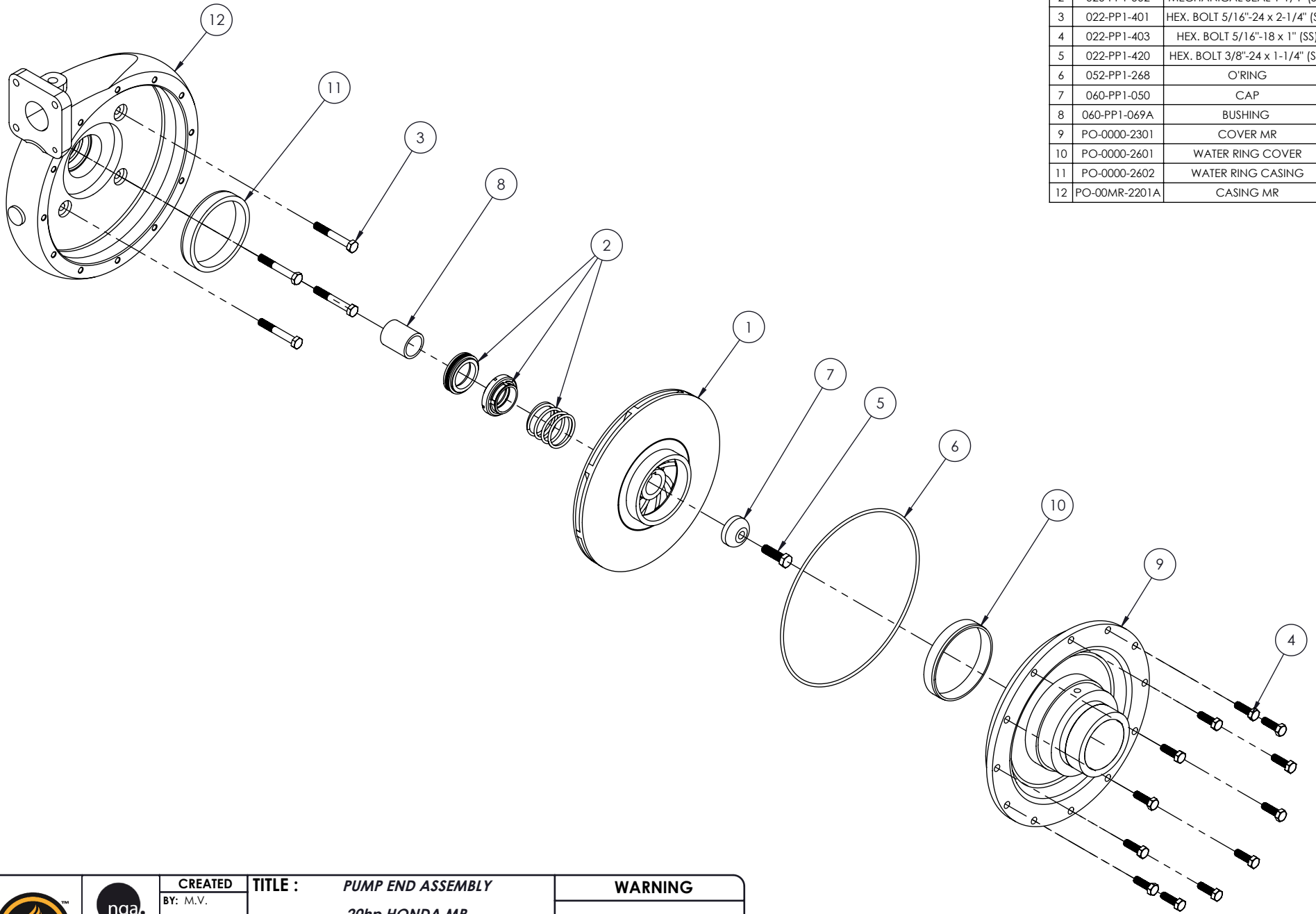

CREATED
 BY: M.V.
 DATE: 19-08-16
VERIFIED
 BY: M.P.
 DATE: 19-08-16

TITLE : PUMP END ASSEMBLY
 20hp HONDA MR
No: PO-42MR-2101

WARNING
 THIS DOCUMENT REMAINS THE PROPERTY OF C.E.T. FIRE PUMPS MFG.
 ALL REPRODUCTION WITHOUT WRITTEN AGREEMENT FROM C.E.T. FIRE PUMPS MFG IS TOTALLY PROHIBITED.

A	Version A	01-01-16	M.P.
REV.	DESCRIPTION	DATE	BY