

**PORTABLE FIRE PUMP**  
**PFP-23hpVGD-2D**  
**380000 VANGUARD WITH HIGH-VOLUME PUMP**

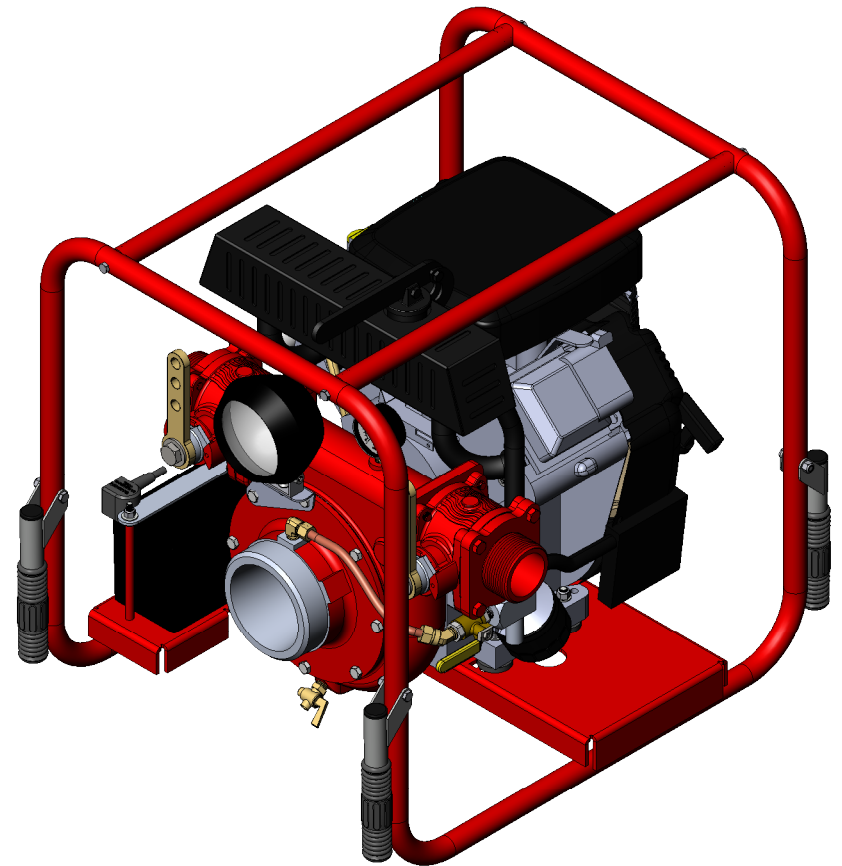

**WE CAN CUSTOMIZE AS YOU WANT**

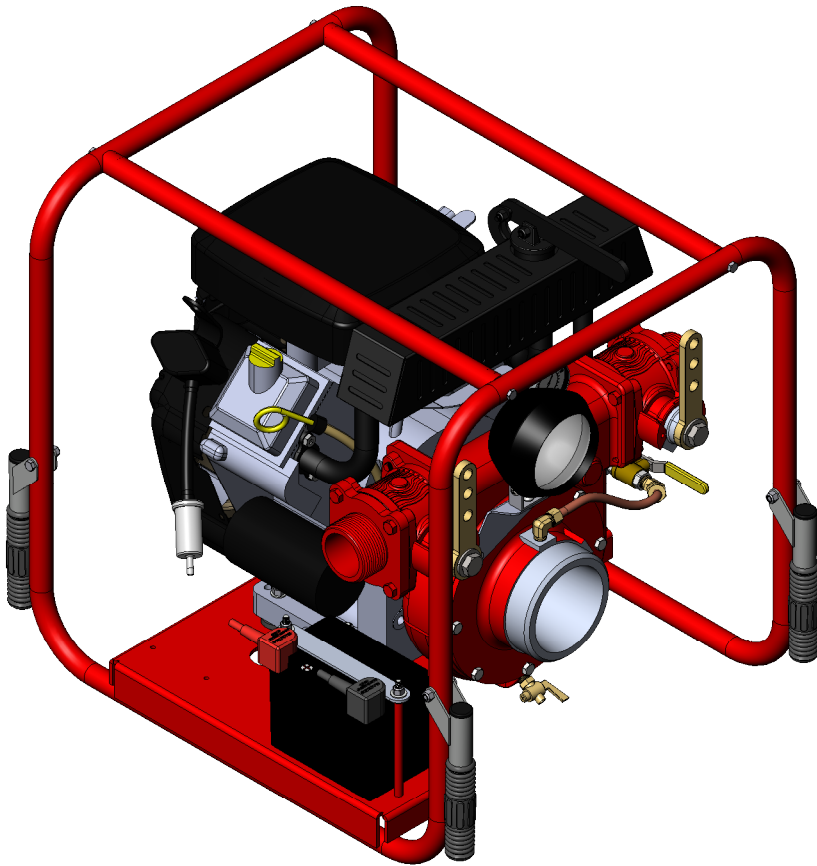
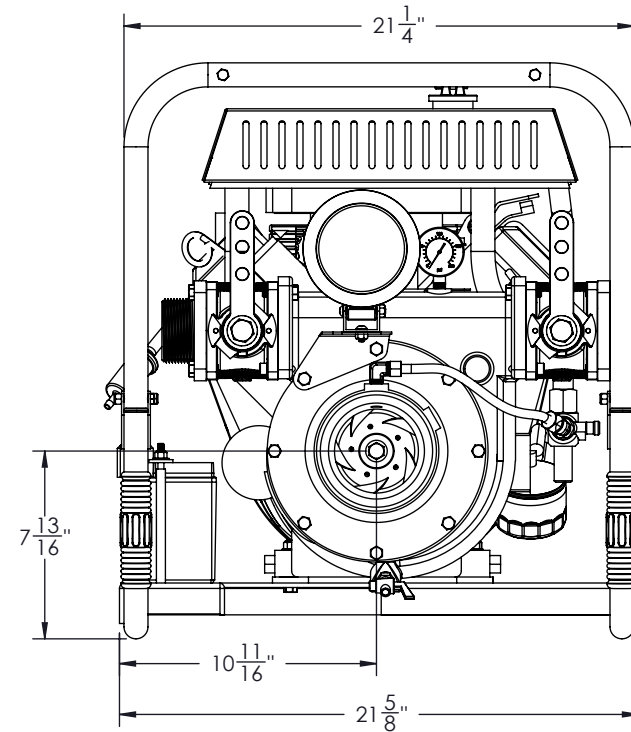
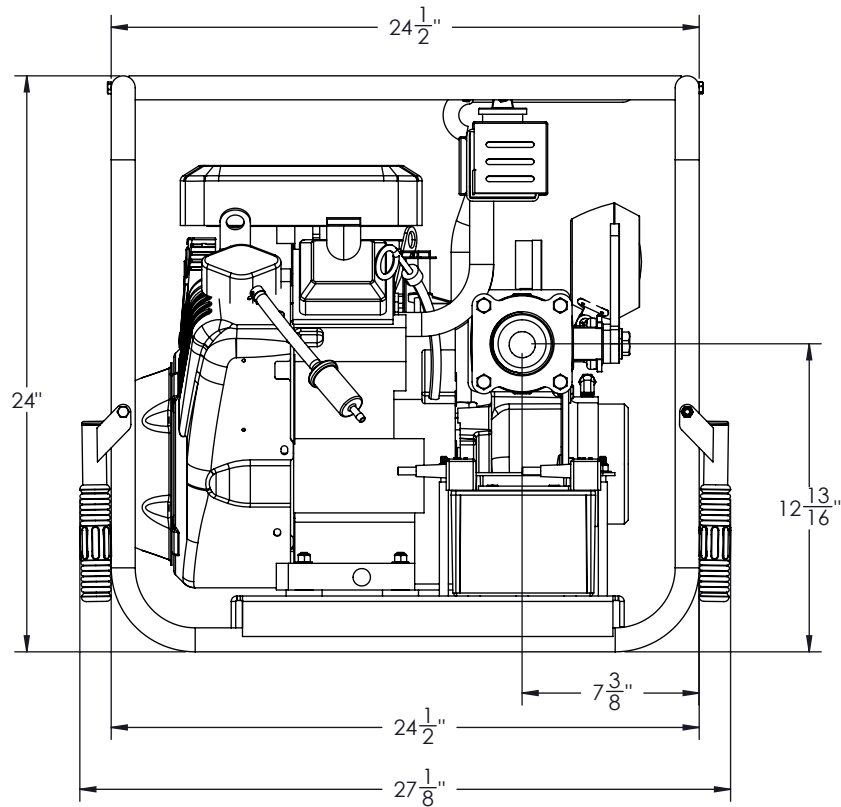

**WET WEIGHT: 185lbs**



**CREATED**  
BY: M.P.  
DATE: 05-08-16  
**VERIFIED**  
BY: M.P.  
DATE: 05-08-16

**TITLE :** PFP-23hpVGD-2D  
FULL FRAME  
**No:** PO-462D-0701-A

**WARNING**

THIS DOCUMENT REMAINS THE PROPERTY OF C.E.T. FIRE PUMPS MFG.  
ALL REPRODUCTION WITHOUT WRITTEN AGREEMENT FROM C.E.T. FIRE PUMPS MFG IS TOTALLY PROHIBITED.

REV.	DESCRIPTION	DATE	BY
A	Version A	01-01-16	M.P.

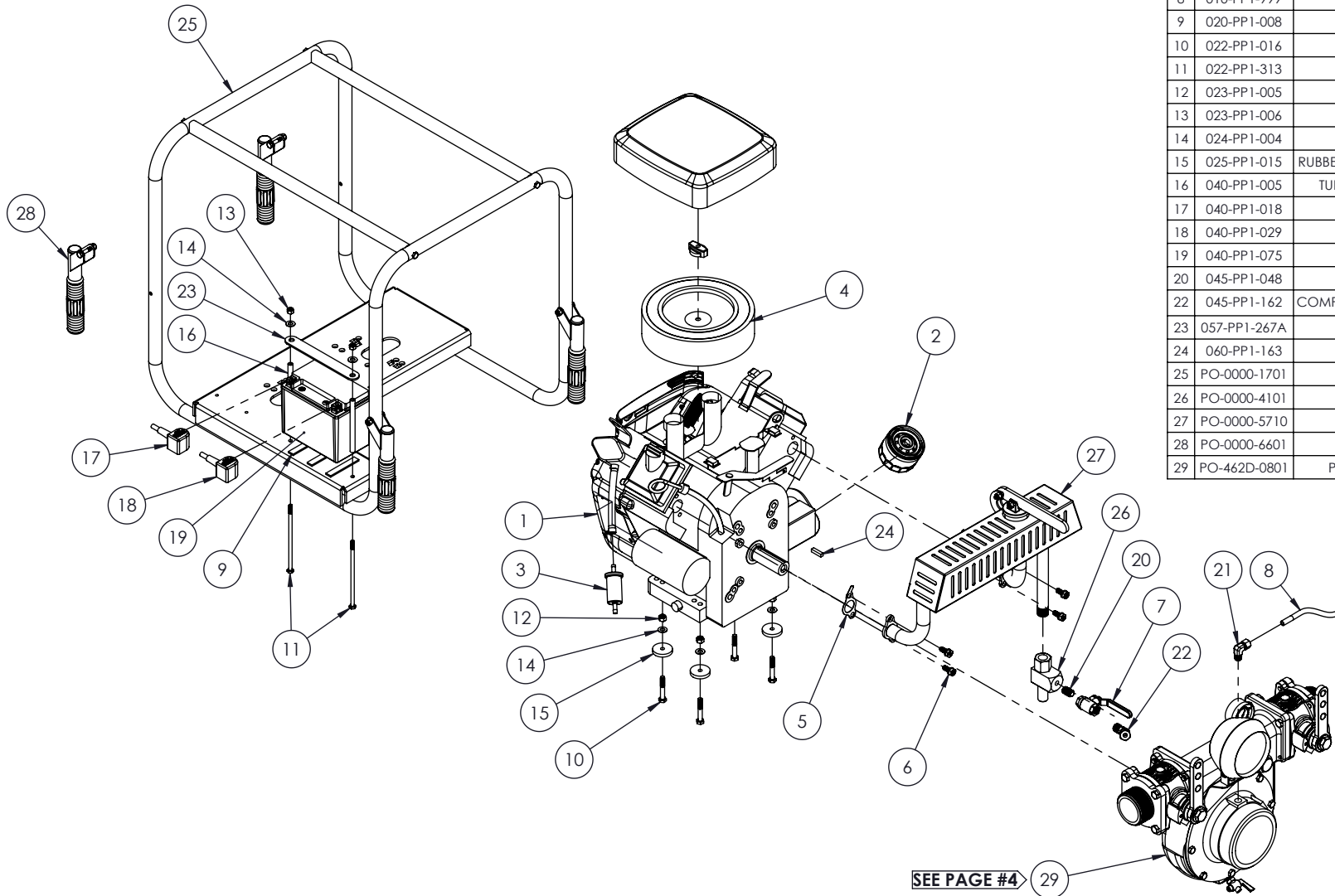

NO	PART NAME	DESCRIPTION	QTY
1	001-PP1-019	380000 VANGUARD ENGINE	1
2	003-PP1-097	OIL FILTER	1
3	003-PP1-124	FUEL FILTER	1
4	003-PP1-126	AIR FILTER	1
5	003-PP1-127	EXHAUST FLANGE	2
6	003-PP1-128	EXHAUST BOLT	4
8	010-PP1-999	COPPER TUBE 3/8" x 7-3/4"	1
9	020-PP1-008	BATTERY FOAM TAPE 1/2" x 3"	3
10	022-PP1-016	HEX BOLT 5/16"-18 x 2"	4
11	022-PP1-313	HEX. BOLT 1/4"-20 x 6"	2
12	023-PP1-005	HEX. NYLON LOCK NUT 5/16"-18	4
13	023-PP1-006	HEX. NYLON LOCKNUT 1/4"-20	2
14	024-PP1-004	FLAT WASHER 5/16" ID x 3/4"OD	6
15	025-PP1-015	RUBBER WASHER 0.312" INT x 1.5" EXT. x 1/4" TK	4
16	040-PP1-005	TUBE for BATTERY ROD 1/4" x 4-3/4" RED	2
17	040-PP1-018	BATTERY CABLE CET-R-7/A	1
18	040-PP1-029	BATTERY CABLE CET-N-10.25	1
19	040-PP1-075	BATTERY 12v	1
20	045-PP1-048	CLOSE NIPPLE 1/4 NPT-M	1
22	045-PP1-162	COMP. 45deg. ELBOW 3/8" TUBE x 1/4" NPT-M	1
23	057-PP1-267A	BATTERY RETAINER PLATE	1
24	060-PP1-163	SHAFT KEY 1/4"	1
25	PO-0000-1701	UNIVERSAL FULL FRAME	1
26	PO-0000-4101	VENTURY	1
27	PO-0000-5710	PUMP MUFFLER	1
28	PO-0000-6601	SMALL HANDLE	4
29	PO-462D-0801	PUMP END ACCESSORIES ASSEMBLY	1

SEE PAGE #4



CREATED  
BY: M.P.  
DATE: 05-08-16  
VERIFIED  
BY: M.P.  
DATE: 05-08-16

TITLE : PFP-23hpVGD-2D  
FULL FRAME  
No: PO-462D-0701-A



WARNING

THIS DOCUMENT REMAINS THE PROPERTY OF C.E.T. FIRE PUMPS MFG.  
ALL REPRODUCTION WITHOUT WRITTEN AGREEMENT FROM C.E.T. FIRE PUMPS MFG IS TOTALLY PROHIBITED.

REV.	DESCRIPTION	DATE	BY
A	Version A	01-01-16	M.P.

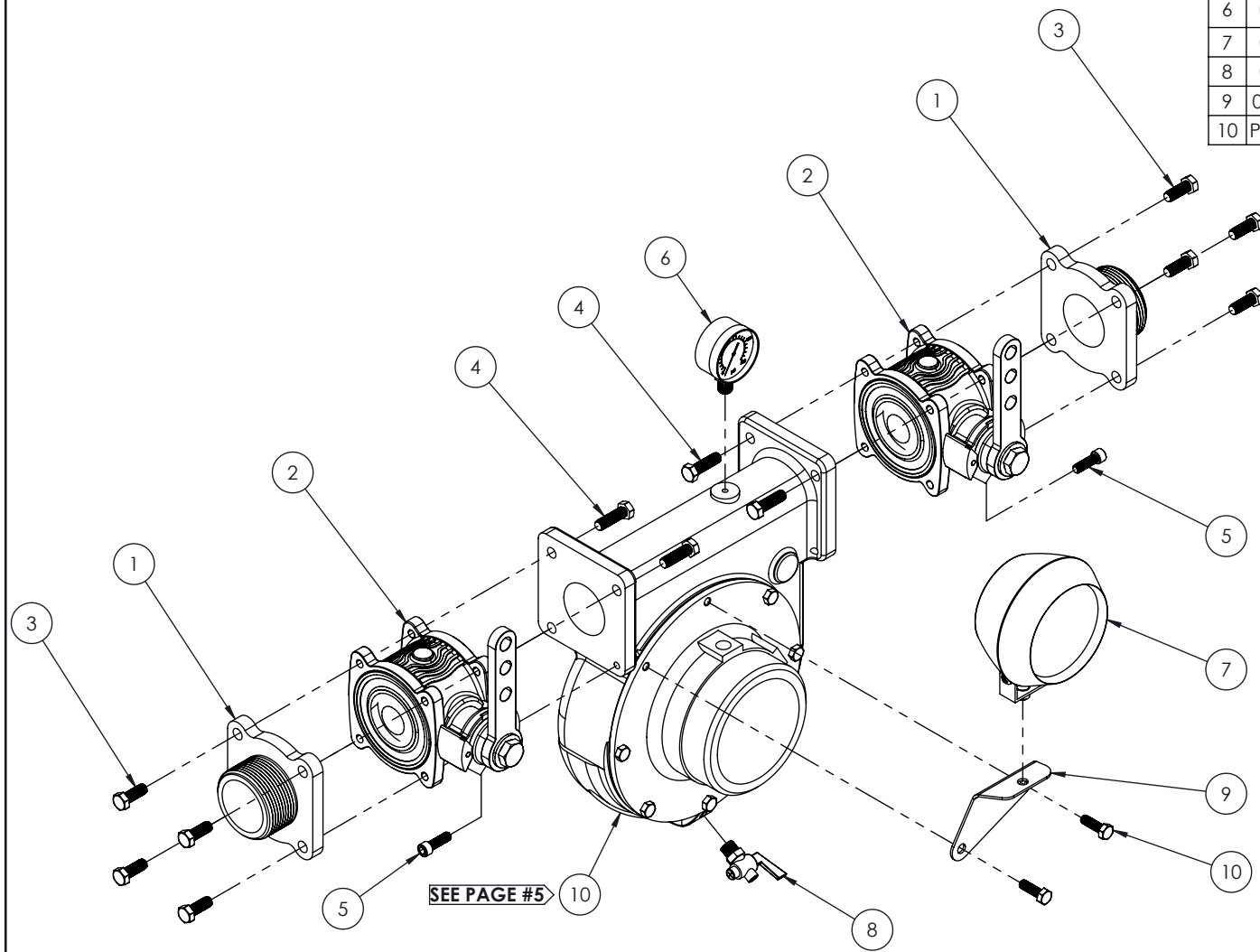
NO	PART NUMBER	DESCRIPTION	QTY
1	002-PP1-302	FLANGE 2-1/2"	2
2	005-PP1-012	FIRE GRADE VALVE 2"	2
3	022-PP1-003	HEX. BOLT 3/8-16 x 1"	8
4	022-PP1-004	HEX. BOLT 3/8"-16 x 1-1/4"	6
5	022-PP1-996	SOCKET HEAD CAP SCREW 5/16"-18 x 1"	2
6	034-PP1-018	DRY GAUGE 0/200psi DIA 2" x 1/4CMB	1
7	040-PP1-004	PAR36 LIGHT	1
8	045-PP1-086	DRAIN VALVE 1/4" NPT-M	1
9	057-PP1-034A	BRACKET LIGHT	1
10	PO-002D-2103	PUMP END ASSEMBLY	1



		<b>CREATED</b> BY: M.P. DATE: 05-08-16	<b>TITLE : PUMP END ACCESSORIES ASSEMBLY</b>  23hpVGD - 2D	<b>WARNING</b>  THIS DOCUMENT REMAINS THE PROPERTY OF C.E.T. FIRE PUMPS MFG.  ALL REPRODUCTION WITHOUT WRITTEN AGREEMENT FROM C.E.T. FIRE PUMPS MFG IS TOTALLY PROHIBITED.	A REV.	Version A  DESCRIPTION	01-01-16  DATE	M.P.  BY
		<b>VERIFIED</b> BY: M.P. DATE: 05-08-16	<b>No:</b> <b>PO-462D-0801</b>					

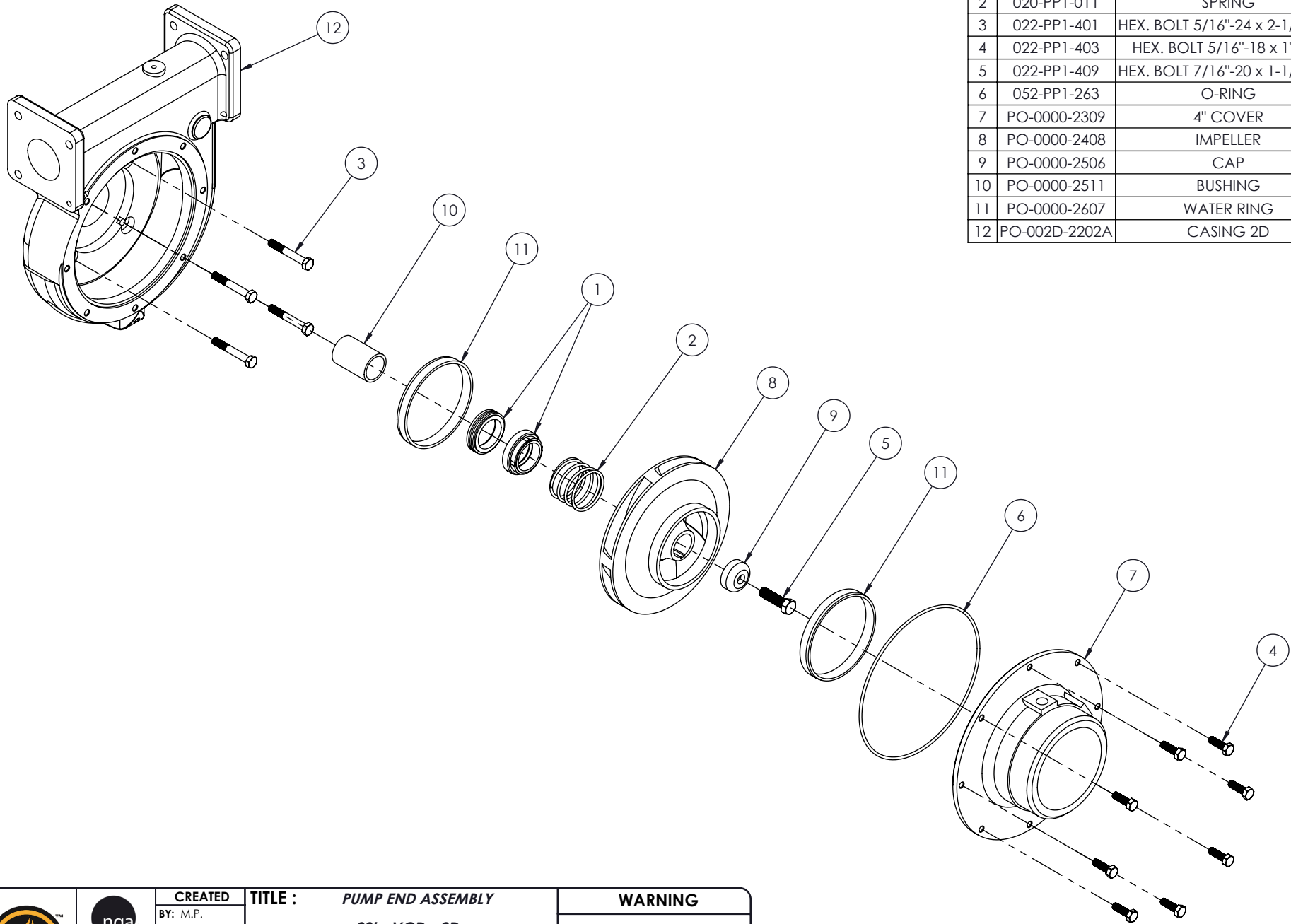

NO	PART NUMBER	DESCRIPTION	QTY
1	020-PP1-003	1.375" T-21 BP1C1 SEALS	1
2	020-PP1-011	SPRING	1
3	022-PP1-401	HEX. BOLT 5/16"-24 x 2-1/4" (SS)	4
4	022-PP1-403	HEX. BOLT 5/16"-18 x 1" (SS)	8
5	022-PP1-409	HEX. BOLT 7/16"-20 x 1-1/2" (SS)	1
6	052-PP1-263	O-RING	1
7	PO-0000-2309	4" COVER	1
8	PO-0000-2408	IMPELLER	1
9	PO-0000-2506	CAP	1
10	PO-0000-2511	BUSHING	1
11	PO-0000-2607	WATER RING	2
12	PO-002D-2202A	CASING 2D	1



**CREATED**  
 BY: M.P.  
 DATE: 05-08-16  
**VERIFIED**  
 BY: M.P.  
 DATE: 05-08-16

**TITLE :** PUMP END ASSEMBLY  
 23hpVGD - 2D  
**No:** PO-002D-2103

**WARNING**  
 THIS DOCUMENT REMAINS THE PROPERTY OF C.E.T. FIRE PUMPS MFG.  
 ALL REPRODUCTION WITHOUT WRITTEN AGREEMENT FROM C.E.T. FIRE PUMPS MFG IS TOTALLY PROHIBITED.

A	Version A	01-01-16	M.P.
REV.	DESCRIPTION	DATE	BY