

SKID MOUNTED FIRE PUMP
SM-PFP-6hpHND-EM-TWIN
GX200 HONDA WITH HIGH-PRESSURE PUMP

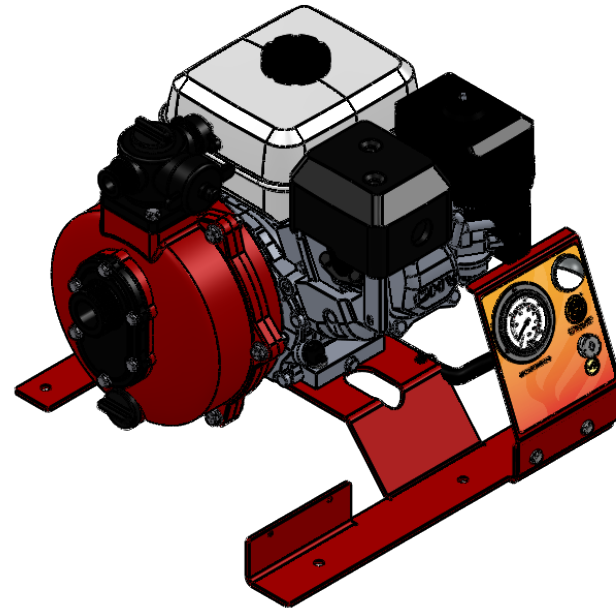

WE CAN CUSTOMIZE AS YOU WANT

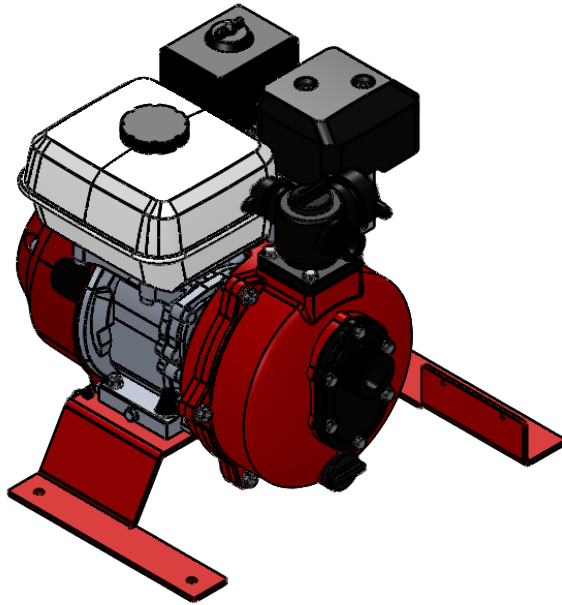
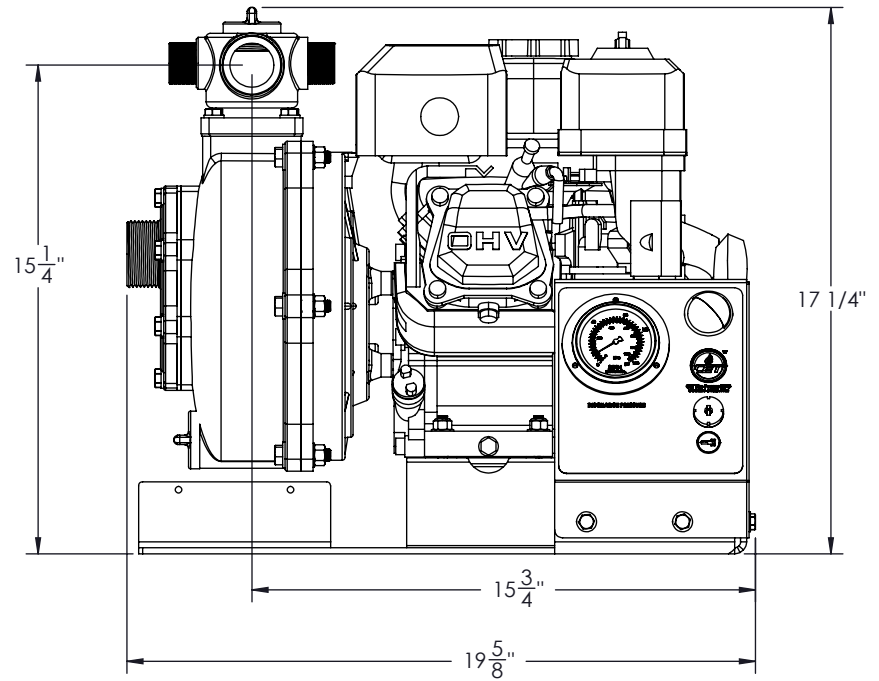
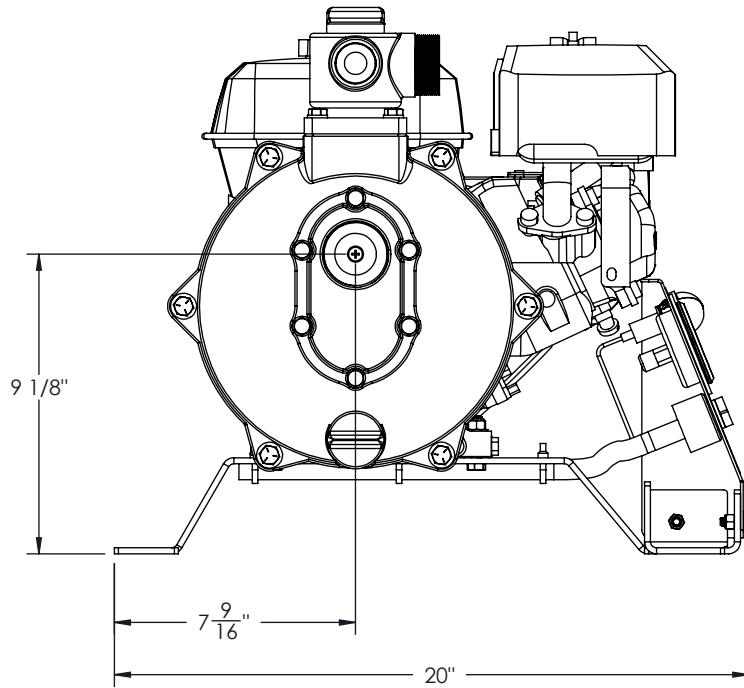

WET WEIGHT: 83 lbs

	CREATED	TITLE : SM-PFP-6hpHND-EM-TWIN	WARNING THIS DOCUMENT REMAINS THE PROPERTY OF C.E.T. FIRE PUMPS MFG. ALL REPRODUCTION WITHOUT WRITTEN AGREEMENT FROM C.E.T. FIRE PUMPS MFG IS TOTALLY PROHIBITED.
	BY: M.V.	SKID FRAME	
	DATE: 22-10-15	No:	
	VERIFIED	PO-03TW-0702-A	
BY: M.P.			
DATE: 11-05-16			

A	Version A	01-01-16	M.P.
REV.	DESCRIPTION	DATE	BY

NO	PART NUMBER	DESCRIPTION	QTY
1	001-PP1-006	HONDA ENGINE (GX200), ELECTRIC/MANUAL 6.5hp GAS	1
2	003-PP1-105	AIR FILTER	1
3	003-PP1-150	AIR FILTER FOAM	1
4	022-PP1-028	HEX. BOLT 5/16"-18 x 1-1/2"	4
5	022-PP1-416	HEX. BOLT 1/4"-20 x 3/4" (SS)	3
6	023-PP1-005	HEX. NYLON LOCK NUT 5/16"-18	4
7	023-PP1-006	HEX. NYLON LOCKNUT 1/4"-20	3
8	024-PP1-004	FLAT WASHER 5/16" ID x 3/4" OD	4
9	024-PP1-404	FLAT WASHER 1/4" ID x 5/8" OD (SS)	3
10	040-PP1-025	CABLE TIE 11"	3
11	057-PP1-314	SKID FRAME	1
12	PO-0000-1624	CONTROL PANEL	1
13	PO-00TW-2101	GOLIATH PUMP	1

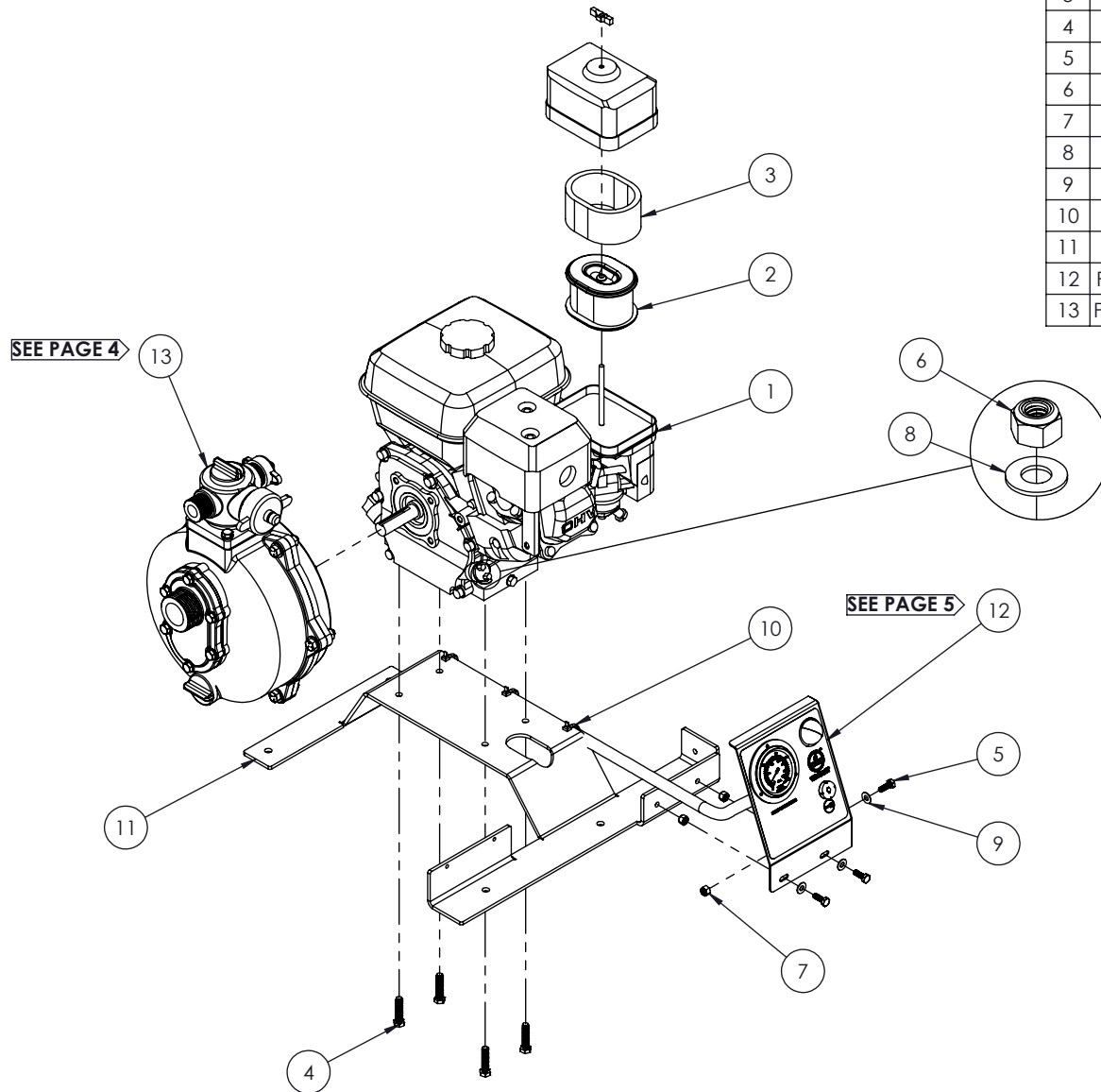

CREATED	TITLE : SM-PPF-6hpHND-EM-TWIN
BY: M.V.	SKID FRAME
DATE: 22-10-15	
VERIFIED	No: PO-03TW-0702-A
BY: M.P.	
DATE: 11-05-16	

WARNING

THIS DOCUMENT REMAINS THE PROPERTY OF C.E.T. FIRE PUMPS MFG.

ALL REPRODUCTION WITHOUT WRITTEN AGREEMENT FROM C.E.T. FIRE PUMPS MFG IS TOTALLY PROHIBITED.

A	Version A	01-01-16	M.P.
REV.	DESCRIPTION	DATE	BY

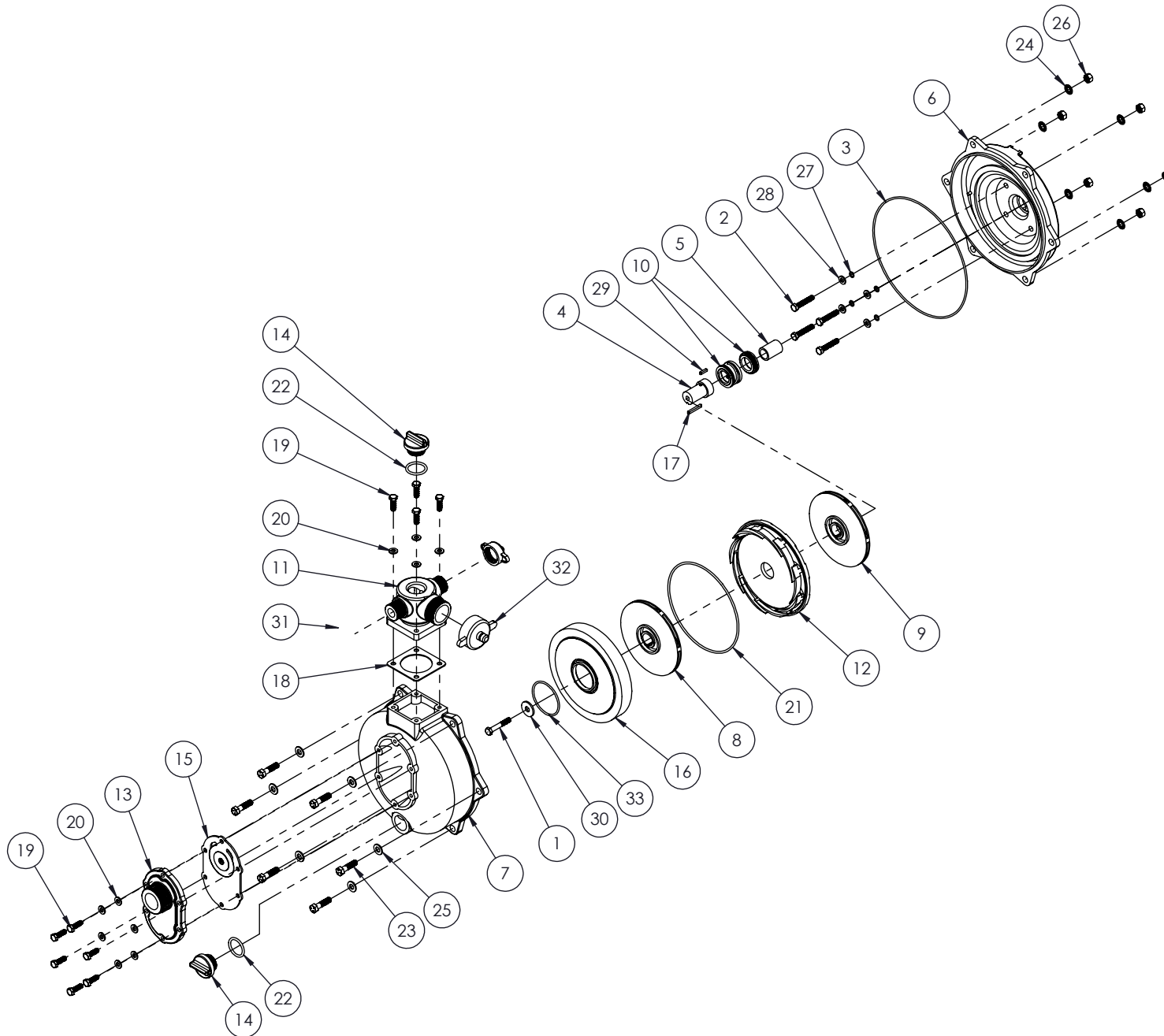

NO	PART NUMBER	DESCRIPTION	QTY
1	022-PP1-414	HEX. BOLT 5/16"-24 x 2" (SS)	1
2	022-PP1-427	HEX. BOLT 5/16"-24 x 1-3/4" (SS)	4
3	052-PP1-001	O-RING	1
4	060-PP1-061	SHAFT EXTENSION	1
5	060-PP1-084	BUSHING	1
6	PO-00TW-2201	CASING	1
7	PO-00TW-2301	COVER	1
8	PO-00TW-2401	FRONT IMPELLER	1
9	PO-00TW-2402	REAR IMPELLER	1
10	PO-00TW-2701	MECHANICAL SEAL	1
11	PO-00TW-2702	MANIFOLD	1
12	PO-00TW-2703	STATOR	1
13	PO-00TW-2801	INTAKE	1
14	PO-00TW-2802	PLUG	2
15	PO-00TW-2803	INTAKE GASKET	1
16	PO-00TW-2804	HIGH PRESSURE IMPELLER COVER	1
17	PO-00TW-2806	IMPELLER KEY	1
18	PO-00TW-2807	MANIFOLD GASKET	1
19	PO-00TW-2808	HEX. BOLT	10
20	PO-00TW-2809	WASHER	10
21	PO-00TW-2810	O-RING	1
22	PO-00TW-2811	O-RING	2
23	PO-00TW-2813	HEX. BOLT	6
24	PO-00TW-2814	INTERNAL LOCK WASHER	6
25	PO-00TW-2815	WASHER	6
26	PO-00TW-2816	HEX. NUT	6
27	PO-00TW-2817	O-RING	4
28	PO-00TW-2818	WASHER	4
29	PO-00TW-2820	SHAFT KEY	1
30	PO-00TW-2822	WASHER	1
31	PO-00TW-2824	1" CAP	1
32	PO-00TW-2825	1-1/2" CAP	1
33	PO-00TW-2826	O-RING	1



CREATED
 BY: M.V.
 DATE: 08-01-15
VERIFIED
 BY: M.P.
 DATE: 30-10-15

TITLE : *GOLIATH PUMP*
for GX200 HONDA
No:
PO-00TW-2101

WARNING
 THIS DOCUMENT REMAINS THE PROPERTY
 OF C.E.T. FIRE PUMPS MFG.
 ALL REPRODUCTION WITHOUT WRITTEN
 AGREEMENT FROM C.E.T. FIRE PUMPS MFG
 IS TOTALLY PROHIBITED.

A	Version A	01-01-16	M.P.
REV.	DESCRIPTION	DATE	BY

NO	PART NUMBER	DESCRIPTION	QTY
1	034-PP1-001	MANOMETER 0 to 160Psi	1
2	055-PP1-017D	STICKER	1
3	PO-0000-1501	CONTROL PANEL	1
4	PO-0000-9605	SWITCH-LIGHT-WIRING	1

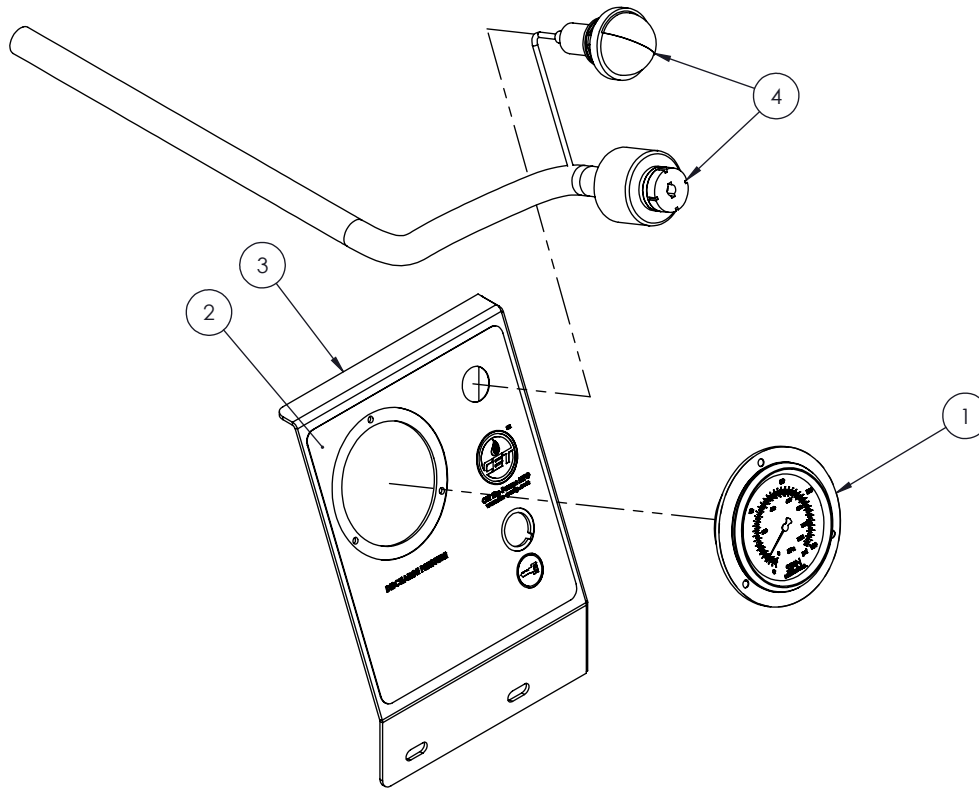

CREATED	TITLE :	CONTROL PANEL
BY: M.P.		6hp HONDA
DATE: 11-05-16		
VERIFIED	No:	PO-0000-1624
BY: M.P.		
DATE: 11-05-16		

WARNING

THIS DOCUMENT REMAINS THE PROPERTY OF C.E.T. FIRE PUMPS MFG.

ALL REPRODUCTION WITHOUT WRITTEN AGREEMENT FROM C.E.T. FIRE PUMPS MFG IS TOTALLY PROHIBITED.

A	Version A	01-01-16	M.P.
REV.	DESCRIPTION	DATE	BY